

DRAFT

AUTOMOTIVE INDUSTRY STANDARD

**Performance Requirements
for Reversing Lamps & Manoeuvring
Lamps for Motor Vehicles**

(Revision 2)

Date of hosting on website: 25th October 2018
Last date for comments: 24th November 2018

INTRODUCTION

- 0.1 The Government of India felt the need for a permanent agency to expedite the publication of standards and development of test facilities in parallel when the work on the preparation of the standards is going on, as the development of improved safety critical parts can be undertaken only after the publication of the standard and commissioning of test facilities. To this end, the erstwhile Ministry of Surface Transport (MOST) has constituted a permanent Automotive Industry Standards Committee (AISC) vide order No. RT-11028/11/97-MVL dated September 15, 1997. The standards prepared by AISC will be approved by the permanent CMVR Technical Standing Committee (CTSC). After approval, the Automotive Research Association of India, (ARAI), Pune, being the Secretariat of the AIS Committee, has published this standard. For better dissemination of this information ARAI may publish this document on their Web site.
- 0.2 Accordingly AIS-012 covering performance requirements of lighting and light-signalling devices for motor vehicles having more than three wheels, trailers and semi-trailers has been published in 2004 and implemented thereafter in 2005.

With technological advancement in lighting and light-signalling devices and updation in ECE regulations, AIS-012 was taken up for revision and now is prepared in ten parts. This part covers performance requirements for reversing lamps for motor vehicles.

- 0.3 While preparing this standard considerable assistance has been derived from following ECE regulation.

This part is based on ECE R 23 – Revision 4 - Amendment 1 Supplement 20 to the original version of the Regulation – Date of entry into force: 8 October 2015	Uniform provisions concerning the approval of reversing lights for power-driven vehicles and their trailers
---	---

- 0.4 The following standards contain provisions, which through reference in this text constitute provisions of the standard.

AIS-053:2005	Automotive Vehicles - Types - Terminology
AIS-008 (Rev.1): 2010	Installation Requirements of Lighting and Light-signalling Devices for Motor Vehicle having more than Three Wheels, Trailer and Semi-trailer excluding Agricultural Tractor and Special Purpose Vehicle
AIS-034 (Part 1) (Rev. 1):2010	Provisions concerning the Approval of Filament Lamps for use in Approved Lamp Units on Power Driven Vehicles and their Trailers
AIS-010 (Part 5) (Rev. 1):2010	Requirements of Chromaticity Co-ordinates of Colour of Light Emitted from Lighting and Light-signalling Devices
AIS-037:2004	Procedure for Type Approval and Establishing Conformity of Production for Safety Critical Components
IEC Publication 60061,	Lamp Caps and Holders together with Gauges for the Control of Interchangeability and Safety.
AIS 130	Provisions concerning the approval of Light Emitting Diode (LED) light sources for use in approved lamp units on power-driven vehicles and their trailers

- 0.5 The AISC panel and Automotive Industry Standards Committee (AISC) responsible for preparation of this standard are given in Annex G and Annex H respectively.

**Performance Requirements
for Reversing Lamps & Manoeuvring Lamps for Motor Vehicles**

Para. No.	Contents	Page No.
0.	Scope	
1.	Definitions	
2.	Application for approval	
3.	Markings	
4.	Approval	
5.	General specifications	
6.	Intensity of light emitted	
7.	Test procedures	
8.	Colour of light emitted	
9.	Modifications of the type of reversing lamps for motor vehicles and their trailers and extension of approval	
10.	Conformity of production	
11.	Penalties for non-conformity of production	
12.	Reserved	
13.	Reserved	
14.	Transitional provisions	
15.	Establishing compliance of “E”/“e” approved reversing lamps to this standard	
16.	Amendments to ECE regulation after the level described in 0.3 of introduction	
List of Annexes		
Annex A	Application for approval	
Annex B	Reserved	
Annex C	Photometric measurements	
Annex D	Colour of white light	
Annex E	Minimum requirements for conformity of production control procedures	
Annex F	Minimum requirements for sampling by a testing agency	

Performance Requirements for Reversing Lamps & Manoeuvring Lamps for Motor Vehicles

0. SCOPE

This standard applies to reversing lamps for vehicles of categories L5, M, N, T and A^{1/}.

(b) Manoeuvring lamps for vehicles of categories M and N.

Note: The permission to use reversing lamps covered by this standard are governed by requirements specified by the standard for installation of requirements of that category of vehicles.

1. DEFINITIONS

For the purposes of this standard,

1.1. The definitions given in AIS-008(Rev.1) and its amendments in force at the time of application for type approval shall apply to this standard.

1.2. "**Reversing lamp**" means the lamp of the vehicle designed to illuminate the road to the rear of the vehicle and to warn other road users that the vehicle is reversing or about to reverse;

1.2. "**Manoeuvring lamp**" means a lamp used to provide supplementary illumination to the side of the vehicle to assist during slow manoeuvres.

1.3. "**Reversing /manoeuvring lamps of different types**" means lamps which differ in such essential respects as:

- (a) The trade name or mark;
- (b) The characteristics of the optical system, (levels of intensity, light distribution angles, category of filament lamp, light source module, etc.);

A change of the colour of the filament lamp or the colour of any filter does not constitute a change of type.

1.4. References made in this standard shall be referred to AIS-034(Part 1) (Rev. 1) and its amendments at the time of application for type approval.

2. APPLICATION FOR APPROVAL

2.1. The application for approval shall be submitted by the applicant.

At the choice of the applicant, it will specify that the device may be installed on the vehicle with different inclinations of the reference axis in respect to the vehicle reference planes and to the ground or rotate around its reference axis; these different conditions of installation shall be indicated in the technical information (see Annex A).

1/ As defined in AIS-053: Automotive Vehicles - Types - Terminology

- 2.2. For each type of reversing lamp, the application shall be accompanied by:
- 2.2.1. drawings, in triplicate, in sufficient detail to permit identification of the type of the reversing lamp or a manoeuvring lamp and showing in what geometrical position(s) the reversing lamp may be mounted on the vehicle; the axis of observation to be taken as the axis of reference in the tests (horizontal angle $H = 0^\circ$, vertical angle $V = 0^\circ$); and the point to be taken as the centre of reference in the said tests. The drawings shall show the position intended for the approval number and the additional symbol in relation to the circle of the approval mark;
In addition the mounting height and the orientation of the reference axis of the manoeuvring lamp(s) shall be indicated in the drawing in relation to the ground, the vertical and the longitudinal axis.
- 2.2.2. A brief technical description stating in particular, with the exception of lamps with non-replaceable light sources:
- (a) The category or categories of filament lamp(s) prescribed; this filament lamp category shall be one of those contained in AIS-034(Part 1)(Rev. 1) and its amendments at the time of application for type approval; and/or
 - (b) The category or categories of LED light source(s) prescribed; this LED light source category shall be one of those contained in AIS 130 and its series of amendments in force at the time of application for type approval; and/or
 - (c) The light source module specific identification code.
- 2.2.3. Two samples. If the devices are not identical but are symmetrical and suitable for mounting one on the left and one on the right side of the vehicle, the two samples submitted may be identical and be suitable for mounting only on the right or only on the left side of the vehicle.

3. MARKINGS

The samples of a type of reversing lamp submitted for approval shall:

- 3.1. Bear the trade name or mark of the lamp manufacturer; this marking shall be clearly legible and be indelible;
- 3.2. With the exception of lamps with non-replaceable light sources bear a clearly legible and indelible marking indicating:
- (a) The category or categories of filament lamp(s) prescribed; and/or
 - (b) The light source module specific identification code.
- 3.3. If necessary in order to prevent any mistake in mounting the reversing lamp on the vehicle, bear the word "TOP" marked horizontally on the uppermost part of the illuminating surface;
- 3.4. Provide adequate space for the approval mark and for the additional symbols; as specified in AIS-037.

- 3.5. In the case of lamps with non-replaceable light sources or light source module(s), bear the marking of rated voltage or the range of voltage, and the rated wattage.

- 3.6. In the case of lamps with light source module(s), the light source module(s) shall bear:
 - 3.6.1. The trade name or mark of the lamp manufacturer; this marking shall be clearly legible and indelible;
 - 3.6.2. The specific identification code of the module; this marking shall be clearly legible and indelible.

This specific identification code shall comprise the starting letters "MD" for "MODULE" followed by the approval marking and in case several non identical light source modules are used, followed by additional symbols or characters;

The approval marking does not have to be the same as the one on the lamp in which the module is used, but both markings shall be from the same lamp manufacturer.

- 3.6.3. The marking of the rated voltage and rated wattage.
- 3.7. On the prototype for type approval, the markings may be provided by suitable temporary methods and need not necessarily be obtained from the tools used for series production.

4. APPROVAL

- 4.1. If the two samples of a type of reversing lamp or a manoeuvring lamp meet the requirements of this standard, approval shall be granted.
- 4.2. An approval number shall be assigned to each type approved lamp.
- 4.3. Every reversing lamp conforming to a type approved under this standard shall bear in the space referred to in paragraph 3.4. above, in addition the mark and the particulars prescribed above in paragraphs 3.1., 3.2. and 3.3. or 3.5. respectively:
 - 4.3.1. An approval number;
 - 4.3.2. An additional symbol consisting of letters A and R, mingled as shown in Annex 2 of ECE regulation 23.
On devices meeting the requirements of this Standard in respect of the manoeuvring lamps, an additional symbol consisting of letters M and L, arranged as shown in Annex 2 of ECE regulation 23.
 - 4.3.3. The first two digits of the approval number which indicate the most recent amendments to this standard may be placed in the vicinity of the additional symbol "AR" or "ML"
 - 4.3.4. On reversing lamps of which the visibility angles are asymmetrical with regard to the reference axis in a horizontal direction, an arrow pointing towards the side on which the photometric specifications are met up to an angle of 45° H.
- 4.4. Independent lamps

If different types of lamps complying with the requirements of several standards use the same outer lens having the same or different colour, a single approval mark may be affixed. This approval mark may be located anywhere on the lamp, provided that:

- 4.4.1. It is visible after their installation.
- 4.4.2. The identification symbol for each lamp appropriate to each standard under which approval has been granted, together with the corresponding amendments incorporating the most recent major technical amendments to the standard at the time of issue of the approval and if necessary, the required arrow shall be marked.
- 4.4.3. The size of the components of a single approval mark shall not be less than the minimum size required for the smallest of the individual marks under which approval has been granted.
- 4.4.4. The main body of the lamp shall include the space described in paragraph 3.4. above and shall bear the approval mark of the actual function(s).
- 4.5. When two or more lamps are part of the same assembly of grouped, combined or reciprocally incorporated lamps, approval is granted only if each of these lamps satisfies the requirements of this standard or of another standard. Lamps not satisfying any one of those standards shall not be part of such an assembly of grouped, combined or reciprocally incorporated lamps.
 - 4.5.1. Where grouped, combined or reciprocally incorporated lamps comply with the requirements of several standards, a single approval mark may be applied. This approval mark may be placed anywhere on the grouped, combined or reciprocally incorporated lamps provided that:
 - 4.5.1.1. It is visible after their installation;
 - 4.5.1.2. No part of the grouped, combined or reciprocally incorporated lamps that transmits light may be removed without at the same time removing the approval mark.
 - 4.5.2. The identification symbol for each lamp appropriate to each standard under which approval has been granted, together with the corresponding amendments incorporating the most recent major technical amendments to the standard at the time of issue of the approval, shall be marked:
 - 4.5.2.1. Either on the appropriate light-emitting surface,
 - 4.5.2.2. Or in a group, in such a way that each lamp of the grouped, combined or reciprocally incorporated lamps may be clearly identified.
 - 4.5.3. The size of the components of a single approval mark shall not be less than the minimum size required for the smallest of the individual marks by a standard under which approval has been granted.

- 4.5.4. An approval number shall be assigned to each type approved lamp.
- 4.6. The mark and symbol referred to in paragraph 4.3.2. shall be indelible and shall be clearly legible even when the reversing lamp is mounted on the vehicle.

In the case of a manoeuvring lamp:

- (a) A space large enough to accommodate the approval mark on the lens or on its protective housing, which shall be legible when the device has been mounted on the vehicle, shall be provided. Other components of the device shall bear the name of the manufacturer and a means of identification. In case of limited space for the approval mark(s) it shall be placed on a part of the vehicle which is permanently connected to the manoeuvring lamp or on the vehicle data plate;
- (b) The space for the approval mark shall be shown on the drawings referred to paragraph 2.2. above or indicated in the application for approval.
- 4.7. Annex 2 gives examples of approval marks for a single lamp (Figure 1) and for grouped, combined or reciprocally incorporated lamps (Figure 2) with all the additional symbols referred to above. The letters A and R may be mingled.

5. GENERAL SPECIFICATIONS

- 5.1. Each sample shall conform to the specifications set forth in the paragraphs below.
- 5.2. Reversing lamps shall be so designed and constructed that in normal use, despite the vibration to which they may then be subjected, they continue to function satisfactorily and retain the characteristics prescribed by this standard.
- 5.3. In case of light source modules, it shall be checked that:
- 5.3.1. The design of the light source module(s) shall be such as:
- (a) The each light source module may only be fitted in no other position than the designated and correct one and may only be removed with the use of tool(s);
- (b) If there are more than one light source module used in the housing for a device, light source modules having different characteristics can not be interchanged within the same lamp housing.
- 5.3.2. The light source module(s) shall be tamperproof.
- 5.3.3. A light source module shall be so designed that regardless of the use of tool(s), it shall not be mechanically interchangeable with any replaceable approved light source
- 5.4. In the case of replaceable filament lamp(s):

- 5.4.1. Any category or categories of filament lamp(s) approved according to AIS-034 (Part 1)(Rev. 1) may be used, provided that no restriction on the use is made in AIS-034 (Part 1)(Rev. 1) and its amendments at the time of application for type approval.
- 5.4.2. The design of the device shall be such that the filament lamp can be fixed in no other position but the correct one.
- 5.4.3. The filament lamp holder shall conform to the characteristics given in IEC Publication 60061. The holder data sheet relevant to the category of filament lamp used, applies.

6. INTENSITY OF LIGHT EMITTED

- 6.1. Intensity of the light specifications for reversing lamps
- 6.1. The intensity of the light emitted by each of the two samples shall be not less than the minima and not greater than the maxima specified below and shall be measured in relation to the axis of reference in the directions shown below (expressed in degrees of angle with the axis of reference).
- 6.2. The intensity along the axis of reference shall be not less than 80 candelas.

- 6.3. The intensity of the light emitted in all directions in which the light may be observed shall not exceed:

300 candelas in directions in or above the horizontal plane;

and, in directions below the horizontal plane:

600 candelas between h-h and 5° D and

8,000 candelas below 5° D.

- 6.4. In every other direction of measurement shown in Annex C to this standard, the luminous intensity shall be not less than the minima specified in that annex.

However, in the case where the reversing lamp is intended to be installed on a vehicle exclusively in a pair of devices, the photometric intensity may be verified only up to an angle of 30° inwards where a photometric value of at least 25 cd shall be satisfied.

This condition shall be clearly explained in the application for approval and relating documents (see paragraph 2. of this standard).

Moreover, in the case where the type approval will be granted applying the condition above, a statement in paragraph 11. "Comments" of the communication form (see Annex A to this standard), will inform that the device shall only be installed in a pair.

- 6.5. In the case of a single lamp containing more than one light source, the lamp shall comply with the minimum intensity required when any one light source has failed and when all light sources are illuminated the maximum intensities shall not be exceeded. A group of light sources, wired so that the failure of any one of them causes all of them to stop emitting light, shall be considered to be one light source.

- 6.6. Intensity of the light specifications for manoeuvring lamps

- 6.2.1. The intensity shall not exceed 500 candelas in all directions in which the light can be observed, when installed in any mounting position specified by the applicant.

- 6.2.2. The device must be so designed that the light emitted directly towards the side, the front or the rear of the vehicle does not exceed 0.5 cd within the angular field as defined below.

- (a) The vertical minimum angle φ min (in degree) is:

$$\varphi \text{ min} = \arctan (1\text{-mounting height}/10); \text{ where h is mounting height in m}$$

- (b) The vertical maximum angle φ max (in degree) is:

$$\varphi \text{ max} = \varphi \text{ min} + 11,3.$$

The measurement shall be limited to a horizontal angle ranging from +90° to -90° with respect to the line which cuts the reference axis and which is perpendicular to the vertical longitudinal plane of the vehicle.

The measurement distance shall be in minimum 3 m.

7. TEST PROCEDURES

7.1. All measurements, photometric and colorimetric, shall be made:

7.1.1. In the case of a lamp with replaceable light source, if not supplied by an electronic light source control gear, with an uncolored standard filament lamp of the category prescribed for the device, supplied with the voltage necessary to produce the reference luminous flux required for that category of filament lamp.

In the case of LED light sources of 6.75 V, 13.5 V or 28.0 V; the luminous flux value produced shall be corrected. The correction factor is the ratio between the objective luminous flux and the mean value of the luminous flux found at the voltage applied

7.1.2. In the case of a lamp equipped with non-replaceable light sources (filament lamps and other), at 6.75 V, 13.5 V or 28.0 V respectively.

7.1.3. In the case of a system that uses an electronic light source control gear, being part of the lamp ^{1/}applying at the input terminals of the lamp the voltage declared by the manufacturer or, if not indicated, 6.75 V, 13.5 V or 28.0 V respectively.

^{1/} For the purpose of this standard "being part of the lamp" means to be physically included in the lamp body or to be external, separated or not, from the lamp body but supplied by the lamp manufacturer as part of the lamp system.

- 7.1.4. In the case of a system that uses an electronic light source control gear not being part of the lamp the voltage declared by the manufacturer shall be applied to the input terminals of the lamp.
- 7.2. The testing agency shall require from the manufacturer the light source control gear needed to supply the light source and the applicable functions.
- 7.3. The voltage to be applied to the lamp shall be indicated in the communication form, specified in Annex A of this standard.
- "7.4. For any lamp, except those equipped with filament lamps, the luminous intensities measured after one minute and after 10 minutes of operation, shall comply with the minimum and maximum requirements. The luminous intensity distribution after one minute and after 10 minutes of operation shall be calculated from the luminous intensity distribution measured after photometric stability has occurred by applying at each test point the ratio of luminous intensities measured at HV after one minute and after 10 minutes and after photometric stability has occurred. "Photometric stability has occurred" means the variation of the luminous intensity for the specified test point is less than 3 per cent within any 15 minute period."
- 7.4. The limits of the apparent surface in the direction of the reference axis of a light-signaling device shall be determined.

8. COLOUR OF LIGHT EMITTED

In the case of reversing lamps the colour of the light emitted inside the field of the light distribution grid defined at paragraph C 2. of Annex C shall be white.

In the case of manoeuvring lamps the colour of the light emitted inside the field of the whole light distribution shall be white.

To check these colorimetric characteristics, the test procedure described in paragraph 7 of this standard shall be applied. Outside this field no sharp variation of colour shall be observed.

However, for lamps equipped with non-replaceable light sources (filament lamps and other), the colorimetric characteristics should be verified with the light sources present in the lamp, in accordance with relevant subparagraphs of paragraph 7.1. of this Standard.

9. MODIFICATIONS OF THE TYPE OF REVERSING LAMP FOR MOTOR VEHICLES AND THEIR TRAILERS AND EXTENSION OF APPROVAL

- 9.1. Every modification pertaining to the information, even if the changes are not technical in nature declared in accordance with 2 shall be intimated by the manufacturer to the testing agency.

If the changes are in parameters not related to the provisions, no further action need be taken.

If the changes are in parameters related to the provisions, the testing agency, which has issued the certificate of compliance, shall then consider, whether,

- 9.1.1 The model with changed specification still complies with provisions, or
- 9.1.2. Any further verification is required to establish compliance.
- 9.2. For considering whether testing is required or not, guidelines given in criteria for extension of approval shall be used (see 9.5).
- 9.3. In case of 9.1.2 above for further verification, only those parameters which are affected by the modifications need be carried out.
- 9.4. In case of fulfilment of 9.1.1 or 9.1.2 above, the approval for compliance shall be extended for the changes carried out.

9.5 **Criteria for extension of approval**

The criteria shall be as agreed between the testing agency and lamp manufacturer.

10. CONFORMITY OF PRODUCTION

- 10.1. Every device bearing an approval mark as prescribed under this standard shall conform to the type approved and shall comply with the requirements of this standard. However, in the case of a device picked at random from series production, the requirements as to the respectively, minimum and maximum intensities of the light emitted (measured with a standard filament lamp as referred to in 6. above) shall be at least 80 per cent of the minimum values specified and not exceed 120 per cent of the maximum values allowed.
- 10.2. The conformity of production procedures shall comply with those set out in the AIS-037 with the following requirements:
 - 10.2.1. During the verification as per 10.2, if tests are required, the following tests shall be carried out:
 - 10.2.1.1. Intensity of light emitted (See 6).
 - 10.2.1.2. Colour of light emitted (See 8).
 - 10.3. Devices with apparent defects are disregarded.
 - 10.4. The reference mark is disregarded.
 - 10.5. The normal frequency of these verifications shall be once every two years.

11. PENALTIES FOR NON-CONFORMITY OF PRODUCTION

Penalties for non-conformity of production shall be as prescribed in AIS-037.

12. Reserved

13. Reserved

14. TRANSITIONAL PROVISIONS^[DN(1)] (To be included later)

15. ESTABLISHING COMPLIANCE OF “E”/“e” APPROVED REVERSING LAMPS TO THIS STANDARD

15.1. As an exception to 7.4 of AIS-037 (or related administrative decisions) for certifying compliance of “E”/ “e” approved direction indicators to this standard, the following test shall be carried out by testing agency.

15.1.1. Photometric requirements measured with a standard filament lamp as referred to in 7 above shall be at least 80 per cent of the minimum values specified and shall not exceed 120 per cent of the maximum values specified in 6.0.

15.1.2. Colourimetric requirements shall be specified in 8.0 within the limits specified.

16. AMENDMENTS TO ECE REGULATION AFTER THE LEVEL DESCRIBED IN 0.3 OF INTRODUCTION

16.1. Supplements

Note: In case of changes in ECE regulation, which are issued as supplements (Supplements do not affect the earlier type approvals) at the request of lamp manufacturer, approval of compliance to this standard shall be issued taking into account the changes arising out of such supplement(s) to ECE regulation with approval from Chairman AISC.

This shall be incorporated in the test report.

Such changes will be considered for inclusion in this standard at the time of its next amendment /revision.

16.2. Series of amendments

Changes in ECE regulation, which are issued as series of amendments (series of amendments may affect the earlier type approvals) will not be considered for issuing approval to this standard.

However, Chairman, AISC may, on a case to case basis, permit to accept latest series of amendments.

This shall be incorporated in the test report.

Note: Such changes will be considered for inclusion in this standard at the time of its next revision.

ANNEX A

(See 2.1)

APPLICATION FOR APPROVAL

Technical information to be submitted by the Applicant
at the time of Approval

- A 1. Trade name or mark of the device:
- A 2. Manufacturer's name for the type of device:
- A 3. Manufacturer's name and address:
.....
- A 4. If applicable, name and address of the manufacturer's
representative:
.....
- A 5. Submitted for approval on:
- A 6. Concise description:
Number, category and kind of light source(s):
Voltage and wattage:
Application of an electronic light source control gear:
(a) Being part of the lamp: yes/no ^{1/}
(b) Being not part of the lamp: yes/no ^{1/}
Input voltage(s) supplied by an electronic light source control gear:
.....
Electronic light source control gear manufacturer and identification number
(when the light source control gear is part of the lamp but is not included into
the lamp body):
.....
Light source module:..... yes/no ^{1/}
Light source module specific identification code:
Geometrical conditions of installation and relating variations; if any:
- A 7. Position of the approval mark:
- A 8. Comments:
This device shall be installed on a vehicle only as part of a pair of
devices: yes/no ^{1/}
- A 9. Place:
- A 10. Date:
- A 11. Signature:
- A 12. The list of documents deposited with the Administrative Service which has
granted approval is annexed to this communication and may be obtained on
request.

1/ Strike out what does not apply.

ANNEX B
(Reserved)

ANNEX C

(See 6.4)

PHOTOMETRIC MEASUREMENTS

C 1. MEASUREMENT METHODS

C 1.1. When photometric measurements are taken, stray reflections shall be avoided by appropriate masking.

C 1.2. In the event that the results of measurements are challenged, measurements shall be taken in such a way as to meet the following requirements:

C 1.2.1. The distance of measurement shall be such that the law of the inverse of the square of the distance is applicable;

C 1.2.2. The measuring equipment shall be such that the angle subtended by the receiver from the reference centre of the light is between 10' and 1°;

C 1.2.3. The intensity requirement for a particular direction of observation shall be satisfied if the required intensity is obtained in a direction deviating by not more than one quarter of a degree from the direction of observation.

C 1.3. In the case where the device may be installed on the vehicle in more than one or in a field of different positions the photometric measurements shall be repeated for each position or for the extreme positions in the field of reference axis specified by the manufacturer.

2. For reversing lamps the measuring points expressed in degrees of angle with the axis of reference and values of the minimum intensities of the light emitted

C 2. MEASURING POINTS EXPRESSED IN DEGREES OF ANGLE WITH THE AXIS OF REFERENCE AND VALUES OF THE MINIMUM INTENSITIES OF THE LIGHT EMITTED

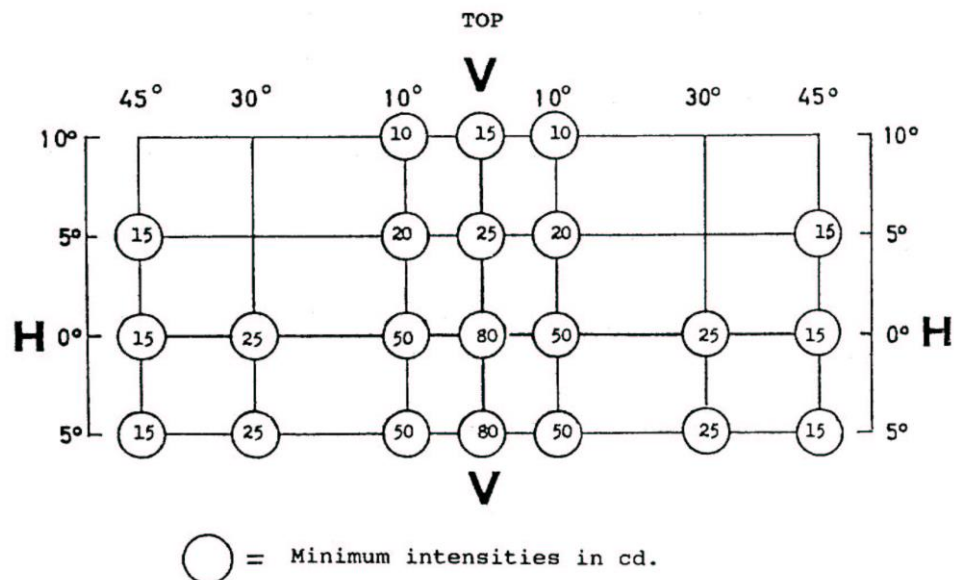

C 2.1. The directions $H = 0^\circ$ and $V = 0^\circ$ correspond to the axis of reference. On the vehicle they are horizontal, parallel to the median longitudinal plane of the vehicle and oriented in the required direction of visibility. They pass through the centre of reference. The values shown in the table give, for the various directions of measurement, the minimum intensities in cd.

C 2.2. If visual examination of a lamp appears to reveal substantial local variations of intensity, a check shall be made to ensure that no intensity measured between two of the directions of measurement referred to above is below 50 per cent of the lower minimum intensity of the two prescribed for these directions of measurement.

C 3. PHOTOMETRIC MEASUREMENT OF LAMPS EQUIPPED WITH SEVERAL LIGHT SOURCES

The photometric performance shall be checked:

C 3.1. For non-replaceable light sources (filament lamps and other):

With the light sources present in the lamp, in accordance with relevant subparagraphs of paragraph 7.1. of this standard.

C 3.2. For replaceable filament lamps:

When equipped with filament lamps at 6.75 V, 13.5 V or 28.0 V, the luminous intensity values produced shall be corrected. For filament lamp the correction factor is the ratio between the reference luminous flux and the mean value of the luminous flux found at the voltage applied (6.75 V, 13.5 V or 28.0 V).

For LED light sources the correction factor is the ratio between the objective luminous flux and the mean value of the luminous flux found at the voltage applied (6.75 V, 13.5 V or 28.0 V).

The actual luminous fluxes of each filament lamp used shall not deviate more than ± 5 per cent from the mean value.

Alternatively a standard filament lamp may be used in turn, in each of the individual positions, operated at its reference flux, the individual measurements in each position being added together.

ANNEX D

(See 8.)

COLOUR OF WHITE LIGHT

For checking these colorimetric characteristics, a source of light at a colour temperature of 2,854° K corresponding to illuminant A of the International Commission on Illumination (ICI) shall be used.

These colorimetric characteristics, shall be measured under conditions described in paragraph 7. of this standard.

However, for lamps equipped with non-replaceable light sources (filament lamps and other), the colorimetric characteristics should be verified with the light sources present in the lamp, in accordance with relevant subparagraphs of paragraph 7.1. of this standard.

The limits of chromaticity co ordinates for white light are as specified in AIS-010(Part 5) (Rev. 1)

ANNEX E

(See 10.)

MINIMUM REQUIREMENTS FOR CONFORMITY OF PRODUCTION CONTROL PROCEDURES

E 1. GENERAL

- E 1.1. The conformity requirements shall be considered satisfied from a mechanical and geometric standpoint, if the differences do not exceed inevitable manufacturing deviations within the requirements of this standard.
- E 1.2. With respect to photometric performances, the conformity of mass-produced lamps shall not be contested if, when testing photometric performances of any lamp chosen at random according to paragraph 7. of this standard, respectively :
- E 1.2.1. No measured value deviates unfavourably by more than 20 per cent from the values prescribed in this standard.
- E 1.2.2. If, in the case of a lamp equipped with a replaceable light source and if results of the test described above do not meet the requirements, tests on lamps shall be repeated using another standard filament lamp.
- E 1.3. The chromaticity coordinates shall be complied when tested under conditions of paragraph 7. of this standard.

E 2. MINIMUM REQUIREMENTS FOR VERIFICATION OF CONFORMITY BY THE MANUFACTURER

For each type of lamp the lamp manufacturer of the approval mark shall carry out at least the following tests, at appropriate intervals. The tests shall be carried out in accordance with the provisions of this standard.

If any sampling shows non-conformity with regard to the type of test concerned, further samples shall be taken and tested. The manufacturer shall take steps to ensure the conformity of the production concerned.

E 2.1. Nature of tests

Tests of conformity in this standard shall cover the photometric and colorimetric characteristics.

E 2.2. Methods used in tests

- E 2.2.1. Tests shall generally be carried out in accordance with the methods set out in this standard.

E 2.2.2. In any test of conformity carried out by the manufacturer, equivalent methods may be used with the consent of the testing agency responsible for approval tests. The manufacturer is responsible for proving that the applied methods are equivalent to those laid down in this standard.

E 2.2.3. The application of paragraphs E 2.2.1. and E 2.2.2. requires regular calibration of test apparatus and its correlation with measurements made by a testing agency.

E 2.2.4. In all cases the reference methods shall be those of this standard, particularly for the purpose of administrative verification and sampling.

E 2.3. **Nature of sampling**

Samples of lamps shall be selected at random from the production of a uniform batch. A uniform batch means a set of lamps of the same type, defined according to the production methods of the manufacturer.

The assessment shall in general cover series production from individual factories. However, a manufacturer may group together records concerning the same type from several factories, provided these operate under the same quality system and quality management.

E 2.4. **Measured and recorded photometric characteristics**

The sampled lamp shall be subjected to photometric measurements for the minimum values at the points listed in Annex C and the chromaticity coordinates.

E 2.5. **Criteria governing acceptability**

The manufacturer is responsible for carrying out a statistical study of the test results and for defining, in agreement with the testing agency, criteria governing the acceptability of his products in order to meet the specifications laid down for verification of conformity of products in paragraph 9.1. of this standard.

The criteria governing the acceptability shall be such that, with a confidence level of 95 per cent, the minimum probability of passing a spot check in accordance with Annex F (first sampling) would be 0.95.

ANNEX F

(See E 2.5)

**MINIMUM REQUIREMENTS FOR SAMPLING
BY A TESTING AGENCY**

F 1. GENERAL

- F 1.1. The conformity requirements shall be considered satisfied from a mechanical and a geometric standpoint, in accordance with the requirements of this standard, if any, if the differences do not exceed inevitable manufacturing deviations.
- F 1.2. With respect to photometric performances, the conformity of mass-produced lamps shall not be contested if, when testing photometric performances of any lamp chosen at random according to paragraph 7. of this standard, respectively:
- F 1.2.1. No measured value deviates unfavourably by more than 20 per cent from the values prescribed in this standard.
- F 1.2.2. If, in the case of a lamp equipped with a replaceable light source and if results of the test described above do not meet the requirements, tests on lamps shall be repeated using another standard filament lamp.
- F 1.2.3. Lamps with apparent defects are disregarded.
- F 1.3. The chromaticity coordinates shall be complied when tested under conditions of paragraph 7. of this standard.

F 2. FIRST SAMPLING

In the first sampling four lamps are selected at random. The first sample of two is marked A, the second sample of two is marked B.

F 2.1. The conformity is not contested

- F 2.1.1. Following the sampling procedure shown in Figure 1 of this annex the conformity of mass-produced lamps shall not be contested if the deviation of the measured values of the lamps in the unfavourable directions are:

F 2.1.1.1. Sample A

A1: One lamp	0 per cent
One lamp not more than	20 per cent
A2: Both lamps more than	0 per cent
But not more than	20 per cent
go to sample B	

F 2.1.1.2. Sample B

B1: Both lamps	0 per cent
----------------	------------

- F 2.1.2. or, if the conditions of paragraph F 1.2.2. for sample A are fulfilled.
- F 2.2. **The conformity is contested**
- F 2.2.1. Following the sampling procedure shown in Figure 1 of this annex the conformity of mass-produced lamps shall be contested and the manufacturer requested to make his production meet the requirements (alignment) if the deviations of the measured values of the lamps are:
- F 2.2.1.1. Sample A
- | | |
|----------------------------|-------------|
| A3: One lamp not more than | 20 per cent |
| One lamp more than | 20 per cent |
| But not more than | 30 per cent |
- F 2.2.1.2. Sample B
- | | |
|------------------------|-------------|
| B2: In the case of A2 | |
| One lamp more than | 0 per cent |
| But not more than | 20 per cent |
| One lamp not more than | 20 per cent |
| B3: In the case of A2 | |
| One lamp | 0 per cent |
| One lamp more than | 20 per cent |
| But not more than | 30 per cent |
- F 2.2.2. or, if the conditions of paragraph F 1.2.2. for sample A are not fulfilled.
- F 2.3. **Non conformity established**
- Conformity shall be contested and paragraph 11. applied if, following the sampling procedure in Figure 1 of this annex, the deviations of the measured values of the lamps are:
- F 2.3.1. Sample A
- | | |
|----------------------------|-------------|
| A4: One lamp not more than | 20 per cent |
| One lamp more than | 30 per cent |
| A5: Both lamps more than | 20 per cent |
- F 2.3.2. Sample B
- | | |
|-----------------------|-------------|
| B4: In the case of A2 | |
| One lamp more than | 0 per cent |
| But not more than | 20 per cent |
| One lamp more than | 20 per cent |
| B5: In the case of A2 | |
| Both lamps more than | 20 per cent |
| B6: In the case of A2 | |
| One lamp | 0 per cent |
| One lamp more than | 30 per cent |

F 2.3.3. or, if the conditions of paragraph F 1.2.2. for samples A and B are not fulfilled.

F 3. REPEATED SAMPLING

In the cases of A3, B2, B3 a repeated sampling, third sample C of two lamps and fourth sample D of two lamps, selected from stock manufactured after alignment, is necessary within two months' time after the notification.

F 3.1. The conformity is not contested

F 3.1.1. Following the sampling procedure shown in Figure 1 of this annex the conformity of mass-produced lamps shall not be contested if the deviations of the measured values of the lamps are:

F 3.1.1.1. Sample C

C1: One lamp	0 per cent
One lamp not more than	20 per cent
C2: Both lamps more than	0 per cent
But not more than go to sample D	20 per cent

F 3.1.1.2. Sample D

D1: In the case of C2 Both lamps	0 per cent
-------------------------------------	------------

F 3.1.2. or, if the conditions of paragraph F 1.2.2. for sample C are fulfilled.

F 3.2. The conformity is contested

F 3.2.1. Following the sampling procedure shown in Figure 1 of this annex the conformity of mass-produced lamps shall be contested and the manufacturer requested to make his production meet the requirements (alignment) if the deviations of the measured values of the lamps are:

F 3.2.1.1. Sample D

D2: In the case of C2 One lamp more than	0 per cent
But not more than	20 per cent
One lamp not more than	20 per cent

F 3.2.1.2. or, if the conditions of paragraph F 1.2.2. for sample C are not fulfilled.

F 3.3. Non conformity established

Conformity shall be contested and paragraph 11. applied if, following the sampling procedure in Figure 1 of this annex, the deviations of the measured values of the lamps are:

- F 3.3.1. Sample C
- | | |
|----------------------------|-------------|
| C3: One lamp not more than | 20 per cent |
| One lamp more than | 20 per cent |
| C4: Both lamps more than | 20 per cent |
- F 3.3.2. Sample D
- | | |
|-------------------------|-------------|
| D3: In the case of C2 | |
| One lamp 0 or more than | 0 per cent |
| One lamp more than | 20 per cent |
- F 3.3.3. Or, if the conditions of paragraph F 1.2.2. for samples C and D are not fulfilled.

Figure 1

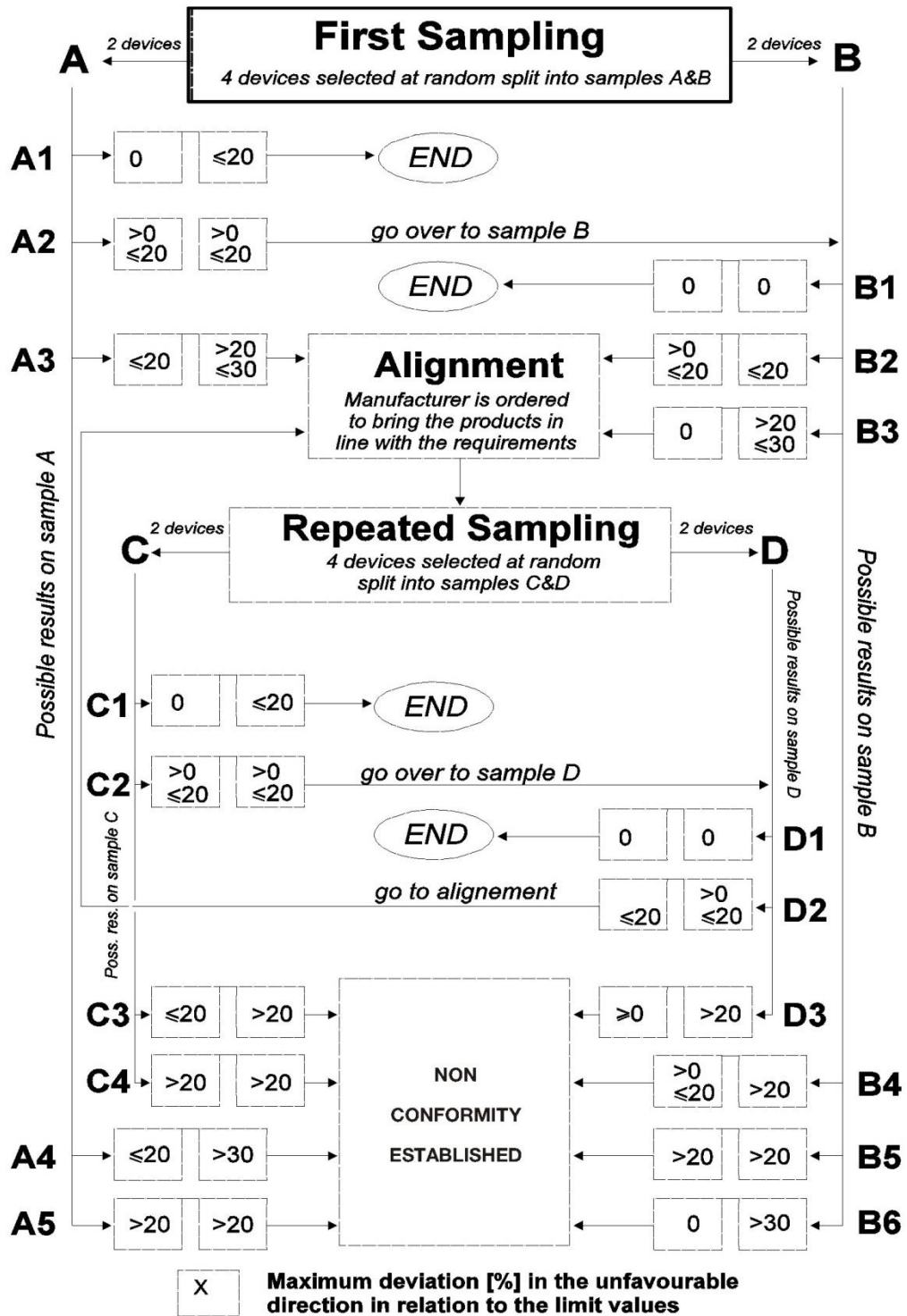

ANNEX G

(See introduction)

**COMPOSITION OF AISC PANEL ON
LIGHTING AND LIGHT SIGNALLING DEVICES***

(To be included)

ANNEX H

(See introduction)

COMMITTEE COMPOSITION*
Automotive Industry Standards Committee

(To be included)