

Date of hosting on website: 30th August 2018
Last date for comment: 14th September 2018

**CHECK LIST FOR PREPARING AUTOMOTIVE INDUSTRY STANDARD
 AIS-038 Part 2**

SR. NO.	PARTICULARS	REMARKS
1.	Indicate details of the base reference standard. (eg. UN Regulation / EC Directive/UN GTR etc.)	R 136
2.	Add an explanatory note indicating differences between the above standard and the draft, if any.	No difference. Based on R136, AIS 038 Part 2 is prepared for L category vehicles
3.	Specify details of technical specifications to be submitted at the time of type approval relevant to the requirements of this standard covered.	As per AIS 007 table 13
4.	Are the details of Worst Case Criteria covered?	Yes
5.	Are the performance requirements covered?	Yes
6.	Is there a need to specify dimensional requirements?	No
7.	If yes, are they covered?	NA
8.	Is there a need to specify COP requirements? If yes, are they covered?	NA
9.	Is there a need to specify type approval, and routine test separately, as in the case of some of the Indian Standards? If yes, are they covered?	NA
10.	If the standard is for a part/component or sub-system; i) AIS-037 or ISI marking scheme be implemented for this part? ii) Are there any requirements to be covered for this part when fitted on the vehicle? If yes, has a separate standard been prepared?	NA
11.	If the standard is intended for replacing or revising an already notified standard, are transitory provisions for re-certification of	Yes, Transitory provisions are covered in this standard

	already certified parts/vehicles by comparing the previous test result, certain additional test, etc. required? If yes, are they included?	
12.	Include details of any other international or foreign national standards which could be considered as alternate standard.	ECE R136
13.	Are the details of accuracy and least counts of test equipment/meters required to be specified? If yes, have they been included?	NA
14.	What are the test equipments for establishing compliance?	Safety probes
15.	If possible, identify such facilities available in India.	ARAI, ICAT, CIRT, VRDE
16.	Are there any points on which special comments or information is to be invited from members? If yes, are they identified?	No
17.	Does the scope of standard clearly identify vehicle categories?	Yes
18.	Has the clarity of definitions been examined?	Yes

AUTOMOTIVE INDUSTRY STANDARDS

Electric Power Train Vehicles- Construction and Functional Safety Requirements for L Category Vehicles

PRINTED BY
THE AUTOMOTIVE RESEARCH ASSOCIATION OF INDIA
P.B. NO. 832, PUNE 411 004

ON BEHALF OF
AUTOMOTIVE INDUSTRY STANDARDS COMMITTEE
UNDER

CENTRAL MOTOR VEHICLE RULES – TECHNICAL STANDING COMMITTEE

SET-UP BY
MINISTRY OF ROAD TRANSPORT & HIGHWAYS
(DEPARTMENT OF ROAD TRANSPORT & HIGHWAYS)
GOVERNMENT OF INDIA

July 2018

Status chart of the Standard to be used by the Purchaser for updating the record

Sr. No.	Corrigenda	Amendment	Revision	Date	Remark	Misc.

General Remarks:

INTRODUCTION

The Government of India felt the need for a permanent agency to expedite the publication of standards and development of test facilities in parallel when the work of preparation of standards is going on, as the development of improved safety critical parts can be undertaken only after the publication of the standard and commissioning of test facilities. To this end, the erstwhile Ministry of Surface Transport (MoST) has constituted a permanent Automotive Industry Standards Committee (AISC) vide order no. RT-11028/11/97-MVL dated September 15, 1997. The standards prepared by AISC will be approved by the permanent CMVR Technical Standing Committee (CTSC). After approval, The Automotive Research Association of India, (ARAI), Pune, being the secretariat of the AIS Committee, has published this standard. For better dissemination of this information, ARAI may publish this standard on their website.

This standard prescribes the requirements for the construction and functional safety of Electric Power Train Vehicles.

Considerable assistance has been taken from UN ECE R 136.

The AISC panel and the Automotive Industry Standards Committee (AISC) responsible for preparation of this standard are given in Annex F and Annex G respectively.

**Electric Power Train Vehicles- Construction and Functional
Safety Requirements for L Category Vehicles**

Contents

Para. No.	Items	Page No.
1	Scope	1/24
2	Definitions	1/24
3	Specification and Tests	1/24
4	Technical Specifications	11/24
5	Transitional Provisions	11/24
List of Annexes		
Annex A	Protection against direct contacts of parts under voltage	12/24
Annex B	Isolation resistance measurement method for vehicle based tests	15/24
Annex C	Withstand Voltage Test	19/24
Annex D	Water resistance test	20/24
Annex E	Confirmation method for function of onboard isolation resistance monitoring system	22/24
Annex F	Composition of AISC Panel	23/24
Annex G	Composition of AISC	24/24

Electric Power Train Vehicles- Construction and Functional Safety Requirements for L Category Vehicles

1. Scope

- 1.1. This standard specifies the construction and functional safety requirements for L categories of electric power train vehicles as defined in Rule 2 (u) of CMVR.

2. Definitions

Refer AIS-049 (Rev 1) - 2016, as amended and revised from time to time, for the definitions. In addition following definitions are referred,

- 2.1 **"Basic insulation"** means insulation applied to live parts for protection against direct contact under fault-free conditions.
- 2.2 **"Double insulation"** means insulation comprising both basic insulation and supplementary insulation.
- 2.3 **"Reinforced insulation"** means insulation of live parts for protection against electric shock equivalent to double insulation. Insulation may comprise several layers which cannot be tested individually as supplementary or basic insulation.
- 2.4 **"Withstand voltage"** means voltage to be applied to a specimen under prescribed test conditions which does not cause breakdown and/or flashover of a satisfactory specimen.
- 2.5 **"Supplementary insulation"** means independent insulation applied in addition to basic insulation for protection against electric shock in the event of a failure of the basic insulation.

3. SPECIFICATION AND TESTS

3.1. Protection against electrical shock

These electrical safety requirements apply to high voltage buses (as defined in AIS-049 (Rev 1) - 2016, as amended and revised from time to time under conditions where they are not connected to external high voltage power supplies.

3.1.1 Protection against direct contact

Protection against direct contact with high voltage live parts shall comply with paragraphs 3.1.1.1 and 3.1.1.2. These protections (solid insulators, barrier, enclosure, etc.) shall not be able to be opened, disassembled or removed without the use of tools.

- 3.1.1.1 For protection of live parts inside the passenger compartment or

luggage compartment, the protection degree IPXXD as given in Annex A shall be provided.

3.1.1.2 Protection of live parts in areas other than the passenger compartment or luggage compartment

3.1.1.2.1 For vehicles with a passenger compartment, the protection degree IPXXB as given in Annex A shall be satisfied.

3.1.1.2.2 For vehicles without passenger compartment, the protection degree IPXXD as given in Annex A shall be satisfied.

In case of open vehicles where luggage compartment and passenger compartment are not clearly distinguished, for protection of live parts inside areas which can be accessed only with use of tools, the protection degree IPXXB shall be provided and for other live parts protection degree IPXXD shall be provided.

Note: Accessing an area by opening a lock with a key is not considered as using a tool

3.1.1.3 **Connectors**

Connectors (including vehicle inlet) are deemed to meet this requirement if:

- (a) They comply with 3.1.1.1. and 3.1.1.2. when separated without the use of tools; or
- (b) They are located underneath the floor and are provided with a locking mechanism; or
- (c) They are provided with a locking mechanism and other components shall be removed with the use of tools in order to separate the connector; or
- (d) The voltage of the live parts becomes equal or below 60 V DC or equal or below 30 V AC (rms) within one second after the connector is separated.

3.1.1.4 **Service disconnect**

For a service disconnect which can be opened, disassembled or removed without tools, it is acceptable if protection degree IPXXB is satisfied under a condition where it is opened, disassembled or removed without tools.

3.1.1.5 **Marking**

3.1.1.5.1 In the case of a REESS having high voltage capability the symbol shown in Figure 1 shall appear on or near the REESS. The symbol background shall be yellow, the bordering and the arrow shall be black.

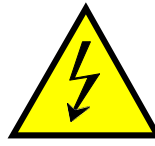

Figure 1
Marking of high voltage equipment

- 3.1.1.5.2 The symbol shall also be visible on enclosures and barriers, which, when removed expose live parts of high voltage circuits. This provision is optional to any connector for high voltage buses. This provision shall not apply to any of the following cases:
- (a) Where barriers or enclosures cannot be physically accessed, opened, or removed; unless other vehicle components are removed with the use of tools;
 - (b) Where barriers or enclosures are located underneath the vehicle floor.
- 3.1.1.5.3 Cables for high voltage buses which are not located within enclosures shall be identified by having an outer covering with the colour orange.
- 3.1.2 **Protection against indirect contact**
- 3.1.2.1 For protection against electrical shock which could arise from indirect contact, the exposed conductive parts, such as the conductive barrier and enclosure, shall be galvanically connected securely to the electrical chassis by connection with electrical wire or ground cable, or by welding, or by connection using bolts, etc. so that no dangerous potentials are produced.
- 3.1.2.2 The resistance between all exposed conductive parts and the electrical chassis shall be lower than 0.1 Ω when there is current flow of at least 0.2 A.
- This requirement is satisfied if the galvanic connection has been established by welding.
- 3.1.2.3 In the case of motor vehicles which are intended to be connected to the grounded external electric power supply through the conductive connection, a device to enable the galvanical connection of the electrical chassis to the earth ground shall be provided. The device shall enable connection to the earth ground before exterior voltage is applied to the vehicle and retain the connection until after the exterior voltage is removed from the vehicle. Compliance to this requirement shall be demonstrated either by using the connector specified by the vehicle

manufacturer, or by analysis.

3.1.2.4. The requirement of paragraph 3.1.2.3. above shall not apply to the vehicles which satisfy (a) or (b) below:

(a) The vehicle's REESS can be charged via the external electric power supply only by using an off-board charger with a double insulation or reinforced insulation structure between input and output.

The performance requirements regarding the previously mentioned insulation structure shall comply with the following requirements of paragraph 3.1.2.4.1. and paragraph 3.1.2.4.3. and stated in its documentation.

(b) The on-board charger has a double or reinforced insulation structure between input and the vehicle's exposed conductive parts/electrical chassis.

The performance requirements regarding the previously mentioned insulation structure shall comply with the following requirements of paragraphs 3.1.2.4.1., 3.1.2.4.2. and 3.1.2.4.3.

If both systems are installed (a) and (b) have to be fulfilled.

3.1.2.4.1. Withstand voltage

3.1.2.4.1.1. For vehicle with on-board charger the test shall be conducted according to Annex C to this standard.

3.1.2.4.1.2. Acceptance criteria

The insulation resistance shall be equal to or greater than 7 MΩ when applying 500 V DC between all the inputs connected together and the vehicle's exposed conductive parts/electrical chassis.

3.1.2.4.2. Protection against ingress of water

3.1.2.4.2.1. This test shall be conducted according to Annex D of this standard.

3.1.2.4.2.2. Acceptance Criteria

The insulation resistance shall be equal to or greater than 7 MΩ, when applying 500 V DC.

3.1.2.4.3. Handling instructions

Appropriate instructions for charging shall be provided and included in the manual*.

*e.g Example of the content in the manual: "If during charging, your vehicle or charger becomes submerged in water you should not touch either the vehicle nor the charger because of danger of electric shock. Also, do not use the battery nor the vehicle and ask your **original vehicle manufacturer authorized representative** to take (appropriate) measures.

3.1.3 **Isolation resistance**

This paragraph shall not apply to chassis connected electrical circuits where the maximum voltage between any live part and the electrical chassis or any exposed conductive part does not exceed 30 V AC (rms) or 60 V DC.

*{*Note: Systems with voltages higher than 30 V AC (rms) or 60 V DC must be isolated from electrical chassis. For systems, where voltages does not exceed 30 V AC (rms) or 60 V DC and if they are isolated from electrical chassis, then below tests as per 3.1.3.1 and 3.1.3.2 shall be applicable.}*

3.1.3.1 Electric power train consisting of separate Direct Current- or Alternating Current-buses. If AC buses and DC buses are galvanically isolated from each other, the isolation resistance between the high voltage bus and the electrical chassis shall have a minimum value of 100 Ω/V of the working voltage for DC buses, and a minimum value of 500 Ω/V of the working voltage for AC buses. The measurement shall be conducted according to Annex B "Isolation resistance measurement method for vehicle based tests".

3.1.3.2 Electric power train consisting of combined DC- and AC-buses. If AC buses and DC buses are galvanically connected, isolation resistance between any high voltage bus and the electrical chassis shall have a minimum value of 500 $\Omega/volt$ of the working voltage.

However, if all AC high voltage buses are protected by one of the two following measures, isolation resistance between any high voltage bus and the electrical chassis shall have a minimum value of 100 Ω/V of the working voltage:

- (a) Double or more layers of solid insulators, barriers or enclosures that meet the requirement in paragraph 3.1.1. independently, for example wiring harness;
- (b) Mechanically robust protections that have sufficient durability over vehicle service life such as motor housings, electronic converter cases or connectors;

The isolation resistance between the high voltage bus and the electrical chassis may be demonstrated by calculation,

measurement or a combination of both.

The measurement shall be conducted according to Annex B "Isolation resistance measurement method for vehicle based tests".

3.1.3.3 **Fuel cell vehicles**

If the minimum isolation resistance requirement cannot be maintained over time, then protection shall be achieved by any of the following:

- (a) Double or more layers of solid insulators, barriers or enclosures that meet the requirement in paragraph 3.1.1. independently;
- (b) On-board isolation resistance monitoring system together with a warning to the driver if the isolation resistance drops below the minimum required value. The isolation resistance between the high voltage bus of the coupling system for charging the REESS and the electrical chassis need not be monitored, because the coupling system for charging is only energized during charging of the REESS. The function of the on-board isolation resistance monitoring system shall be confirmed as described in Annex E.

3.1.3.4 Isolation resistance requirement for the coupling system used to charge the REESS

For the coupling system (used to charge the REESS and intended to be conductively connected to the grounded external AC power supply) the isolation resistance shall be at least 1 M Ω when the charger coupler is disconnected. During the measurement, the REESS may be disconnected.

3.2 **Rechargeable Energy Storage System (REESS)**

3.2.1 The REESS shall be approved as per AIS 048:2009 **as amended from time to time.**

3.2.2 Accumulation of gas

Spaces for open type traction batteries that may produce hydrogen gas shall be equipped with a ventilation fan, a ventilation duct or any other suitable means to prevent the accumulation of hydrogen gas.

3.2.3 Protection against electrolyte spills

Vehicles shall foresee that no spilled electrolyte from the REESS and its components shall reach the driver, rider or passenger or

any person around the vehicle during normal condition of use and/or functional operation.

When the REESS is in the upside-down position, no electrolyte shall spill.

3.2.4 Accidental or unintentional detachment:

The REESS and its components shall be installed in the vehicle in such a way so as to preclude the possibility of inadvertent or unintentional detachment of the REESS.

The REESS in the vehicle shall not be ejected when the vehicle is tilted.

The REESS components shall not be ejected when the REESS is put upside down.

3.3 Functional safety

A momentary indication shall, as minimum, be given to the driver when the vehicle is in "active driving possible mode".

However, this provision does not apply under conditions where an internal combustion engine directly or indirectly provides the vehicle's propulsion power.

When leaving the vehicle, the driver shall be informed by a signal (e.g. optical or audible signal) if the vehicle is still in the active driving possible mode.

{Note: The condition shall be deemed to be satisfied if the indication specified above is not momentary and continues to be displayed. }

If the onboard REESS can be externally charged by the user, movement caused by the vehicle's propulsion system shall not be possible while the external electric power supply is physically connected to the vehicle inlet.

For vehicles with a permanently connected recharge cable, the requirement above is not applicable if using the cable to charge the vehicle prevents the use of the vehicle (e.g. seat cannot be closed, the cable position does not allow the rider to sit in or step into the vehicle). This requirement shall be demonstrated by using the connector specified by the vehicle manufacturer. The state of the drive direction control unit shall be identified to the driver.

The state of the drive direction control unit shall be identified to the driver.

- 3.3.1 Additional functional safety requirements
 - 3.3.1.1 At least two deliberate and distinctive actions shall be performed by the driver at the start-up to select the active driving possible mode.
 - 3.3.1.2 Only a single action shall be required to deactivate the active driving possible mode.
 - 3.3.1.3 Indication of temporary reduced power (i.e. not resulting from a failure) and/or of state of charge (SOC) of REESS.
 - 3.3.1.3.1 The vehicle shall have a function/device that indicates to the driver/rider if the power is automatically reduced below a certain level, (e.g. due to activation of the output controller to protect the REESS or the propulsion system) or due to a low SOC.
 - 3.3.1.3.2 The conditions under which these indications are given shall be determined by the manufacturer.

A brief description of the power reduction and indicating strategy shall be prescribed by manufacturer in technical specifications as per clause no 4.0

- 3.3.1.4 Driving or riding backwards
 - It shall not be possible to activate the vehicle reverse control function whilst the vehicle is in forward motion.
- 3.3.1.5 There shall also be an optical / visual indication to the driver when state of charge of the REESS reaches a level where re-charging is recommended, this indication shall remain ON, even if the vehicle is restarted, till the vehicle is charged above the charge level where re-charging is recommended. In case vehicle has an indicator or display which shows continuously the state-of-charge (SOC) level of REESS to the driver, the provision of indication mentioned in this clause is optional.

3.4 **Creepage Distance Measurement for Open Type REESS**

This clause deals with additional leakage current hazard between the connection terminals of a REESS module including any conductive fittings attached to them and any conductive parts, due to the risk of electrolyte spillage in normal operating conditions. It does not apply to traction batteries, for which electrolyte leakage will not occur under normal operating conditions e.g. sealed traction batteries.

The minimum creepage distance shall be as follows:

a)	In the case of a creepage distance between two battery connection terminals:
	$d \geq 0.25 U + 5$;
	Where d is the creepage distance measured on the tested REESS in mm. U is the nominal voltage between the two battery connection terminals in V.
b)	In the case of creepage distance between live parts and the electrical chassis:
	$d \geq 0.125 U + 5$;
	Where d is the creepage distance measured between the live part and the electrical chassis in mm. U is the nominal voltage between the two battery connection terminals in V.

3.5 **Protection against Water Effects**

The test as per 3.5.1, 3.5.2 and 3.5.3 shall be performed. After each exposure (vehicles still wet), the vehicle shall then comply with the isolation resistance test with at least 100 Ω/V of nominal voltage, but keeping the power equipment connected to the REESS (main switch closed), and before water test isolation resistance with at least 500 Ω/V of nominal voltage.

These tests shall not apply to vehicles having chassis connected electrical circuits where the maximum voltage between any live part and the electrical chassis or any exposed conductive part does not exceed 30V AC (rms) or 60 V DC.

3.5.1 **Washing**

This test is intended to simulate a normal washing of Electric Power Train vehicles, but not specific cleaning using high water pressure or underbody washing. The vehicle manufacturer shall specify detailed conditions for such specific cleaning or washing in the owner's manual. The critical areas of the vehicle regarding this test are border lines i.e. a seal of two parts as flaps, glass seals, outline of opening parts, outline of front grille, seals of lamps.

In the case of open vehicles such as 3-wheelers without doors and windows, or 2-wheelers etc the manufacturer shall specify the procedure for normal washing also. In such cases, the washing test shall be conducted by taking into account the above recommendation.

The test uses a hose nozzle according to IPX5 as specified in IEC 60529 (Refer Annex-D Figure 1 for details). Using fresh water with a flow rate of 12.5 l/min, all borderlines shall be exposed and followed in all directions with the water stream at a speed rate of 0.1 m/s, keeping a distance of 3 m between the nozzle aperture and the borderline.

3.5.2 **Flooding**

This test is intended to simulate the driving of an Electric Power Train vehicles on flooded streets or in water puddles.

The vehicle shall be driven in a wade pool, 10 cm in depth, over a distance of 500 m at a speed of 20 km/h resulting in a time of approximately 1.5 min.

If the wade pool used is less than 500 m in length, so that it has to be driven through several times, the total time including the periods outside the wade pool shall be less than 10 min.

3.5.3 **Heavy Rainstorm**

This test is intended to simulate a sudden heavy rainstorm e.g. a thunderstorm, when opening parts especially to access to the passenger, load and motor compartments are open except those requiring one or more tools.

In case of voltage class B equipment shielded from exposure to water, this test of the whole vehicle may be replaced by equivalent tests on the components individually.

The critical areas of the vehicle regarding this test are those accessible with opened opening parts. This test uses a spray nozzle according to IPX3 as specified in IEC 60529.

Using fresh water with a flow rate of 10 l/min, all surfaces with normally open opening parts shall be exposed for 5 min, possibly through a regular movement of the spray nozzle.

Note: Voltage class B equipment is an equipment with nominal voltage (U)

DC: $60 \text{ V} < U \leq 1500 \text{ V}$

AC: $30 \text{ V rms} < U \leq 1000 \text{ V rms} - 15 \text{ to } 150 \text{ Hz}$

4.0 TECHNICAL SPECIFICATIONS

The details of technical specification, approvals of changes in specification shall be as per para 5.0 of AIS-049 (Rev 1) - 2016, as amended and revised from time to time.

5.0 TRANSITIONAL PROVISIONS

5.1 General guidelines for transitional provisions for this standard shall be as per AIS-000, as amended from time to time, as applicable, with the following additional requirements.

5.2 Type approvals issued to L Category vehicles for compliance to ~~AIS-038 (Part 1) (Rev.1) 2015~~ shall be extended to approval of AIS-038 (Part 2) subject to satisfactory compliance of the following:

5.2.1 Clause 3.1.1 Protection against direct contact

5.2.2 Clause 3.1.2.3 for motor vehicles intended to be connected to the grounded external electric power is met.

5.2.3 Clause 3.1.2.4 for motor vehicles intended to be connected to the non-grounded external electric power is met.

5.2.4 Clause 3.2.2 for removal of accumulated hydrogen gas

5.2.5 Protection against electrolyte spills as per clause 3.2.3

5.2.6 Accidental or unintentional detachment as per clause 3.2.4

5.2.7 Vehicle driving when vehicle connected to charging as per clause 3.3

5.2.8 Additional functional safety requirement as per clause 3.3.1

5.2.9 Minimal SOC indication as per clause 3.3.1.5

ANNEX-A
(See 3.1.1.1)

**PROTECTION AGAINST DIRECT CONTACTS OF PARTS
UNDER VOLTAGE**

1. Access probes

Access probes to verify the protection of persons against access to live parts are given in Table 1.

2. Test conditions

The access probe is pushed against any openings of the enclosure with the force specified in Table 1. If it partly or fully penetrates, it is placed in every possible position, but in no case shall the stop face fully penetrate through the opening.

Internal barriers are considered part of the enclosure.

A low-voltage supply (of not less than 40 V and not more than 50 V) in series with a suitable lamp should be connected, if necessary, between the probe and live parts inside the barrier or enclosure.

The signal-circuit method should also be applied to the moving live parts of high voltage equipment.

Internal moving parts may be operated slowly, where this is possible.

3. Acceptance conditions

The access probe shall not touch live parts.

If this requirement is verified by a signal circuit between the probe and live parts, the lamp shall not light.

In the case of the test for IPXXB, the jointed test finger may penetrate to its 80 mm length, but the stop face (diameter 50 mm x 20 mm) shall not pass through the opening. Starting from the straight position, both joints of the test finger shall be successively bent through an angle of up to 90 degrees with respect to the axis of the adjoining section of the finger and shall be placed in every possible position.

In case of the tests for IPXXD, the access probe may penetrate to its full length, but the stop face shall not fully penetrate through the opening.

TABLE 1
ACCESS PROBES FOR THE TESTS FOR PROTECTION OF PERSONS
AGAINST ACCESS TO HAZARDOUS PARTS

First numeral	Addit. letter	Access probe (Dimensions in mm)	Test force
2	B	<p>Jointed test finger</p> <p>Stop face (∅ 50 x 20)</p> <p>∅ 12</p> <p>See Fig.1 for full dimensions</p> <p>Insulating material</p> <p>Jointed test finger (Metal)</p> <p>80</p>	10 N±10%
4, 5, 6	D	<p>Test wire 1.0 mm diameter, 100 mm long</p> <p>Sphere 35±0.2</p> <p>Approx. 100</p> <p>100±0.2</p> <p>∅ 10</p> <p>Handle (Insulating material)</p> <p>Stop face (Insulating material)</p> <p>Rigid test wire (Metal)</p> <p>Edges free from burrs</p> <p>∅ 1 +0.05 / 0</p>	1N±10%

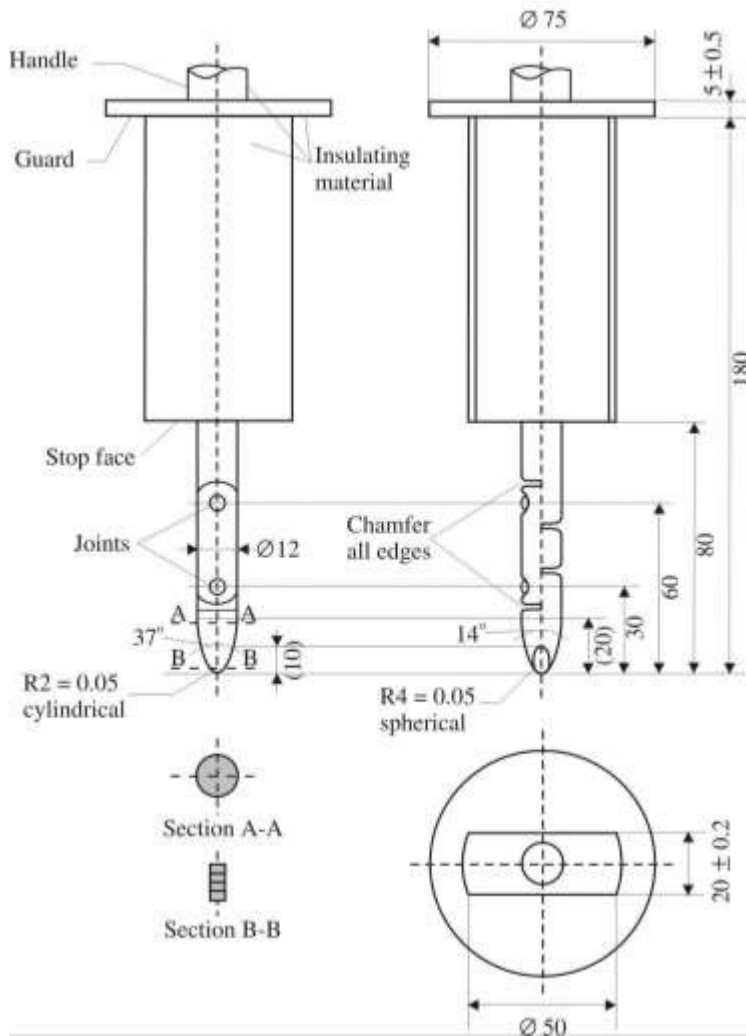

Figure 1
JOINTED TEST FINGER

Material: metal, except where otherwise specified Linear dimensions in millimeters

Tolerances on dimensions without specific tolerance:

- (a) On angles: 0/-10°;
- (b) On linear dimensions: up to 25 mm: 0/-0.05 mm over 25 mm: ±0.2 mm

Both joints shall permit movement in the same plane and the same direction through an angle of 90° with a 0 to +10° tolerance.

ANNEX B
(See 3.1.3.1)

**ISOLATION RESISTANCE MEASUREMENT METHOD FOR
VEHICLE BASED TESTS**

1. General

The isolation resistance for each high voltage bus of the vehicle shall be measured or shall be determined by calculation using measurement values from each part or component unit of a high voltage bus (hereinafter referred to as the "divided measurement").

2. Measurement method

The isolation resistance measurement shall be conducted by selecting an appropriate measurement method from among those listed in paragraphs 2.1. through 2.2. of this annex, depending on the electrical charge of the live parts or the isolation resistance, etc.

The range of the electrical circuit to be measured shall be clarified in advance, using electrical circuit diagrams, etc.

Moreover, modification necessary for measuring the isolation resistance may be carried out, such as removal of the cover in order to reach the live parts, drawing of measurement lines, change in software, etc.

In cases where the measured values are not stable due to the operation of the on-board isolation resistance monitoring system, etc., necessary modification for conducting the measurement may be carried out, such as stopping of the operation of the device concerned or removing it. Furthermore, when the device is removed, it shall be proven, using drawings, etc., that it will not change the isolation resistance between the live parts and the electrical chassis.

Utmost care shall be exercised as to short circuit, electric shock, etc., for this confirmation might require direct operations of the high-voltage circuit.

2.1. Measurement method using voltage from off-vehicle sources

2.1.1. Measurement instrument

An isolation resistance test instrument capable of applying a DC voltage higher than the working voltage of the high voltage bus shall be used.

2.1.2. Measurement method

An insulator resistance test instrument shall be connected

between the live parts and the electrical chassis.

Then, the isolation resistance shall be measured by applying a DC voltage at least half of the working voltage of the high voltage bus. If the system has several voltage ranges (e.g. because of boost converter) in galvanically connected circuit and some of the components cannot withstand the working voltage of the entire circuit, the isolation resistance between those components and the electrical chassis can be measured separately by applying at least half of their own working voltage with those component disconnected.

2.2. Measurement method using the vehicle's own REESS as DC voltage source

2.2.1. Test vehicle conditions

The high voltage-bus shall be energized by the vehicle's own REESS and/or energy conversion system and the voltage level of the REESS and/or energy conversion system throughout the test shall be at least the nominal operating voltage as specified by the vehicle manufacturer.

2.2.2. Measurement instrument

The voltmeter used in this test shall measure DC values and shall have an internal resistance of at least 10 M Ω .

2.2.3. Measurement method

2.2.3.1. First step

The voltage is measured as shown in Figure 1 and the high voltage bus voltage (V_b) is recorded. V_b shall be equal to or greater than the nominal operating voltage of the REESS and/or energy conversion system as specified by the vehicle manufacturer.

2.2.3.2. Second step

Measure and record the voltage (V_1) between the negative side of the high voltage bus and the electrical chassis (see Figure 1).

2.2.3.3. Third step

Measure and record the voltage (V_2) between the positive side of the high voltage bus and the electrical chassis (see Figure 1).

2.2.3.4. Fourth step

If V_1 is greater than or equal to V_2 , insert a standard known resistance (R_o) between the negative side of the high voltage bus and the electrical chassis. With R_o installed, measure the voltage (V_1') between the negative side of the high voltage bus and the electrical chassis (see Figure 2).

Calculate the electrical isolation (R_i) according to the following formula:

$$R_i = R_o * (V_b / V_1' - V_b / V_1) \text{ or } R_i = R_o * V_b * (1 / V_1' - 1 / V_1)$$

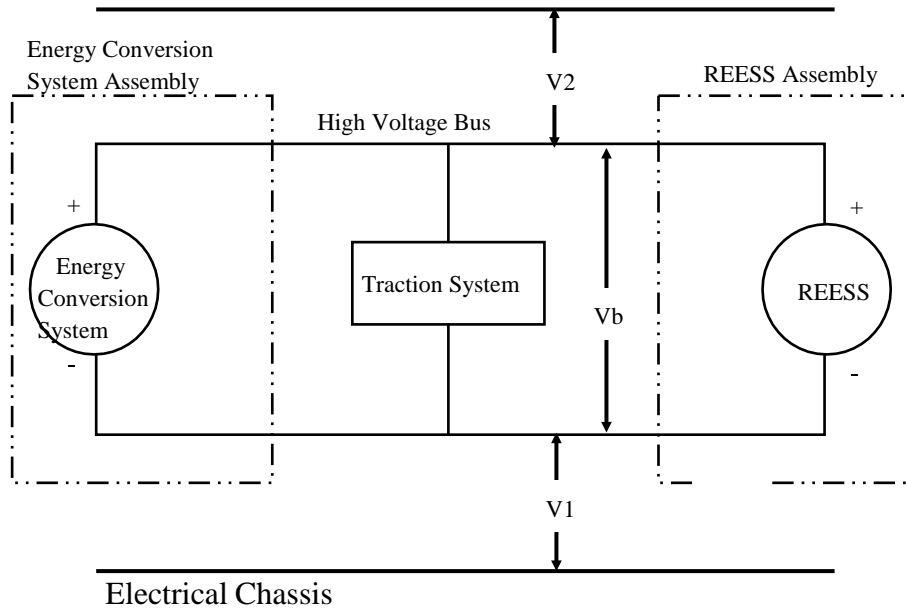

Figure 1
Measurement of V_b , V_1 , V_2

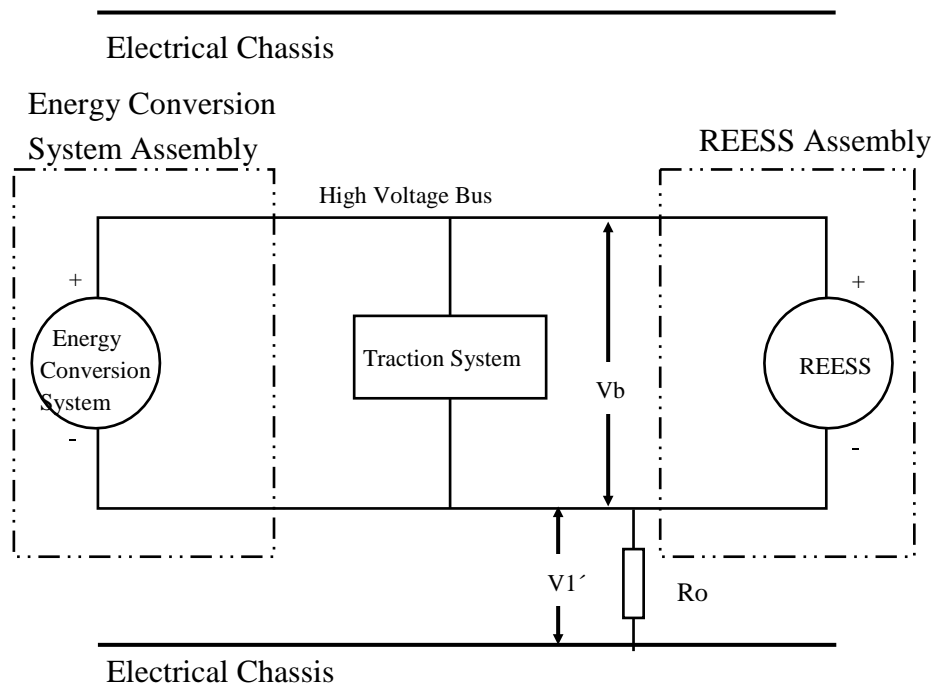

Figure 2
Measurement of V_1'

If V_2 is greater than V_1 , insert a standard known resistance (R_o)

between the positive side of the high voltage bus and the electrical chassis. With R_o installed, measure the voltage (V_2') between the positive side of the high voltage bus and the electrical chassis (see Figure 3). Calculate the electrical isolation (R_i) according to the formula shown. Divide this electrical isolation value (in Ω) by the nominal operating voltage of the high voltage bus (in Volts).

Calculate the electrical isolation (R_i) according to the following formula: $R_i = R_o \cdot (V_b/V_2' - V_b/V_2)$ or $R_i = R_o \cdot V_b \cdot (1/V_2' - 1/V_2)$

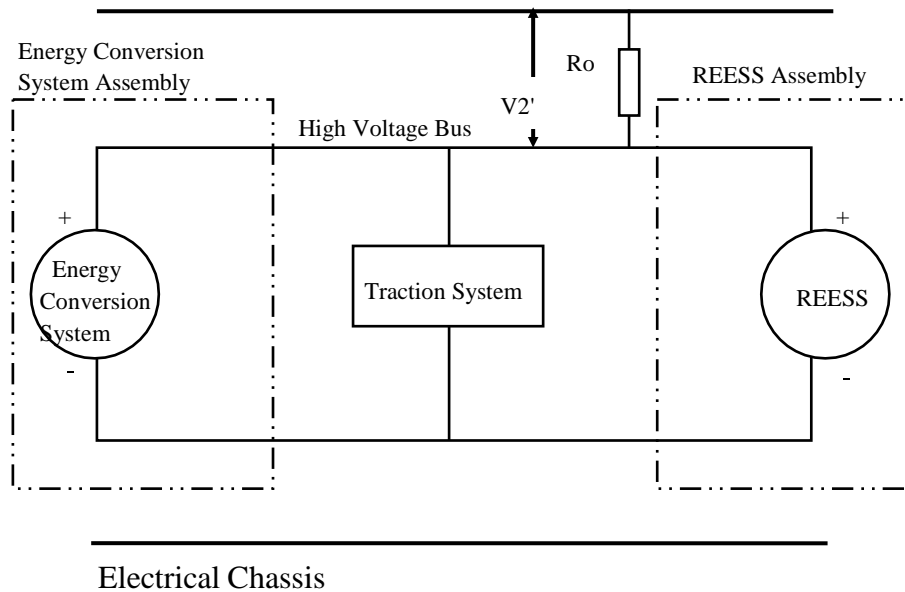

Figure 3
Measurement of V_2'

2.2.3.5. Fifth step

The electrical isolation value R_i (in Ω) divided by the working voltage of the high voltage bus (in Volts) results in the isolation resistance (in Ω/V).

Note: The standard known resistance R_o (in Ω) should be the value of the minimum required isolation resistance (in Ω/V) multiplied by the working voltage of the vehicle plus/minus 20 per cent (in volts). R_o is not required to be precisely this value since the equations are valid for any R_o ; however, a R_o value in this range should provide good resolution for the voltage measurements.

ANNEX C

(See 3.1.2.4.1.1)

WITHSTAND VOLTAGE TEST

1. General

Insulation resistance shall be measured after application of the test voltage to the vehicle with the on-board (built-in) charger.

2. Procedure

The following testing procedure shall be applicable to vehicles with on-board (built-in) chargers:

Between all the inputs of the charger (plug) and the vehicle's exposed conductive parts including the electrical chassis if present, apply a AC test voltage of $2 \times (U_n + 1200)$ V rms at a frequency of 50 Hz or 60 Hz for one minute, where U_n is the AC input voltage (rms);

The test shall be performed on the complete vehicle; All the electrical devices shall be connected.

Instead of the specified AC voltage, the DC voltage whose value is equivalent to the specified AC voltage's peak value may be applied for one minute.

After the test, measure the insulation resistance when applying 500 V D.C. between all the inputs and the vehicle's exposed conductive parts including the electrical chassis if present.

ANNEX D
(See 3.1.2.4.2)

WATER RESISTANCE TEST

1. General

The isolation resistance shall be measured after the water resistance performance test has been conducted.

2. Procedure

The following testing procedure shall be applicable to vehicles with on-board (built-in) charger.

In accordance with the test procedure to evaluate IPX5 protection against ingress of water, the water resistance shall be carried out by:

(a) Spraying with a stream of fresh water the enclosure from all practicable directions with a standard test nozzle as shown in Figure 1.

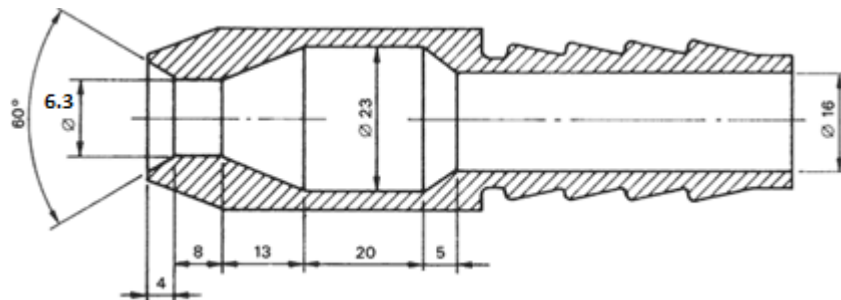

Figure 1 – Hose nozzle dimension

Test device to verify protection against water jets (hose nozzle)

The conditions to be observed are as follows:

- (i) Internal diameter of the nozzle: 6.3 mm;
- (ii) Delivery rate: 12.5 l/min \pm 5 per cent;
- (iii) Water pressure: to be adjusted to achieve the specified delivery rate;
- (iv) Core of the substantial stream: circle of approximately 40 mm diameter at 2.5 m distance from nozzle;
- (v) Test duration per square metre of enclosure surface area likely to be

sprayed: 1 min;

(vi) Minimum test duration: 3 min;

(vii) Distance from nozzle to enclosure surface: between 2.5 m and 3 m.

(b) Subsequently, apply 500 V DC between all high voltage inputs and the vehicle's exposed conductive parts/electrical chassis if present to measure the isolation resistance.

ANNEX E
(See 3.1.3.3)

**CONFIRMATION METHOD FOR FUNCTION OF ON-BOARD
ISOLATION RESISTANCE MONITORING SYSTEM**

The function of the on-board isolation resistance monitoring system shall be confirmed by the following method:

Insert a resistor that does not cause the isolation resistance between the terminal being monitored and the electrical chassis to drop below the minimum required isolation resistance value. The warning shall be activated.

ANNEX F
(See Introduction)

**COMPOSITION OF AISC PANEL ON
ELECTRIC POWER TRAIN VEHICLES- CONSTRUCTION
AND FUNCTIONAL SAFETY REQUIREMENTS* Convener**

Mr. A.A. Deshpande	The Automotive Research Association of India (ARAI)
Members	Representing
Mr. M. M. Desai	The Automotive Research Association of India (ARAI)
TBD	TBD

ANNEX G
(See Introduction)

COMMITTEE COMPOSITION *
Automotive Industry Standards Committee Chairperson

Mrs. Rashmi Urdhwareshe	Director The Automotive Research Association of India, Pune
Members	Representing
Representative from	Ministry of Road Transport and Highways (Dept. of Road Transport and Highways), New Delhi
Representative from	Ministry of Heavy Industries and Public Enterprises (Department of Heavy Industry), New Delhi
TBD	TBD