

**AUTOMOTIVE INDUSTRY STANDARD**

**Requirements of  
Driver's Field of Vision  
for Agricultural Tractors**

PRINTED BY

THE AUTOMOTIVE RESEARCH ASSOCIATION OF INDIA

P. B. NO. 832, PUNE 411 004

ON BEHALF OF

AUTOMOTIVE INDUSTRY STANDARDS COMMITTEE

UNDER

CENTRAL MOTOR VEHICLE RULES – TECHNICAL STANDING COMMITTEE

SET-UP BY

MINISTRY OF SHIPPING, ROAD TRANSPORT & HIGHWAYS

(DEPARTMENT OF ROAD TRANSPORT & HIGHWAYS)

GOVERNMENT OF INDIA

April 2009

**Status chart of the Standard to be used by the purchaser  
for updating the record**

<b>Sr. No.</b>	<b>Corrigenda.</b>	<b>Amendment</b>	<b>Revision</b>	<b>Date</b>	<b>Remark</b>	<b>Misc.</b>

**General Remarks :**

## INTRODUCTION

The Government of India felt the need for a permanent agency to expedite the publication of standards and development of test facilities in parallel when the work on the preparation of the standards is going on, as the development of improved safety critical parts can be undertaken only after the publication of the standard and commissioning of test facilities. To this end, the erstwhile ministry of surface transport (MOST) has constituted a permanent Automotive Industry Standards Committee (AISC) vide order No.RT-11028/11/97-MVL dated September 15, 1997. The standard prepared by AISC will be approved by the permanent CMVR Technical Standing Committee (CTSC). After approval, the Automotive Research Association of India (ARAI), Pune, being the Secretariat of the AIS Committee, has published this standard. For better dissemination of this information ARAI may publish this document on their web site.

At present there is no standard available in India for ensuring safety of operator w.r.t. driver's field of vision. There is a standard for measurement of visibility parameters, but no limit is defined. Hence Tractor Manufacturers Association (TMA) / AISC / CMVR-TSC have decided to formulate this AIS for driver's field of vision for Agricultural Tractors.

While preparing this AIS considerable assistance is derived from the following international standards.

ECE R 71	Uniform provisions concerning the approval of Agricultural Tractors with regard to the driver's field of vision.
EEC Directive 74/347/EEC	Council directive on the approximation of the laws of the Members States relating to the field of vision and windscreen wipers for wheeled agricultural or forestry tractors.

The Automotive Industry Standards Committee responsible for preparation of this standard is given in Annex: I.

## Requirements of Driver's Field of Vision for Agricultural Tractors

### 1. SCOPE

This regards to requirements of safe driving and clear forward field of vision for tractors. This standard applies to the 180-degree forward field of vision of the drivers of agricultural tractors.

### 2. PURPOSE

To establish the adequacy of tractors concerning clear direct forward field of vision of driver by scientific means.

### 3. DEFINITIONS

3.1 **"Forward Field of vision"** means all forward and lateral directions in which the driver of the tractor can see.

3.2 **"Reference point"** means the position, fixed by convention, of the tractor driver's eyes notionally located at a single point. The reference point is situated in the plane parallel to the longitudinal median plane of the tractor and passing through the centre of the seat, 700 mm vertically above the line of intersection of that plane and the surface of the seat and 270 mm in the direction of the pelvic support from the vertical plane passing through the front edge of the surface of the seat and perpendicular to the longitudinal median plane of the tractor (Figure1). The reference point thus determined related to the seat when unoccupied and fitted in the central position specified by the tractor manufacturer.

3.3 **"Semi-circle of vision"** means the semi-circle described by a radius of 12 m around the point situated in the horizontal plane of the road, vertically below the reference point so that the arc -seen from the direction in which the vehicle travels - is situated in front of the tractor and that the diameter delimiting the semi-circle forms a right angle with the longitudinal axis of the tractor (see figure 2).

3.4 **"Masking effect"** means the chords of the sectors of the semi-circle of vision which cannot be seen owing to structural components such as roof- pillars, air intakes or exhaust stacks, frame of the windscreen and protective frame.

3.5 **"Sector of Vision"** means that part of the field of vision bounded:

3.5.1 at the top,

by a horizontal plane passing through the reference point;

3.5.2 in the plane of road,

by the zone lying outside the semi-circle of vision and forming the continuation of the sector of the semicircle of vision, the chord of which is 9.5 m long, perpendicular to the plane parallel to the longitudinal median plane of the tractor passing through the center of driver seat and bisected by the plane.

## 4. REQUIREMENTS

### 4.1 General

The tractor shall be constructed and equipped in such a way that, in road traffic and in farm and forest use, the driver has an adequate field of vision, under all the usual conditions pertaining to highway use and to work undertaken in fields and forests. The field of vision is considered adequate when the driver has, as far as possible, a view of part of each front wheel and when the following requirements are fulfilled.

Note: For tractor fitted with front mud guard/chassis type construction / side seating arrangement (i.e. car type seating) front wheel vision shall not be considered as evaluative requirement for field of vision.

### 4.2 Checking of the field of vision

#### 4.2.1 Procedure for determining masking effects

4.2.1.1 The tractor shall be placed on a horizontal surface as shown in Figure 2. On a horizontal support level with the reference point, there shall be mounted two point sources of light e.g. 2 x 150 W, 12 V, 65 mm apart and symmetrically located with respect to the reference point. The support shall be rotatable at its centre point about a vertical axis passing through the reference point. For the purpose of measuring the masking effects, the support shall be so aligned that the line joining the two light sources is perpendicular to the line joining the masking component and the reference point.

The silhouette (deeper shadow) overlaps projected on to the semi-circle of vision by the masking component when the light sources are switched on simultaneously or alternately shall be recorded in accordance with 3.4 (Figure 3).

4.2.1.2 Masking effects shall not exceed 1600 mm.

4.2.1.3 Masking effects due to adjacent structural components over 80 mm in width shall be so configured that there is an interval of not less than 550 mm – measured as a chord of the semi-circle of vision-between the centres of two masking effects.

4.2.1.4 There may be no more than six masking effects in the semi-circle of vision and no more than two inside the sector of vision defined in clause 3.5.

4.2.1.5 Outside the sector of vision, masking effects exceeding 1600 mm but not exceeding 1800 mm are however, permissible if the components causing them cannot be redesigned or relocated: on each side there may be a total of either two such masking effects, one not exceeding 1600 mm and the other not exceeding 1800 mm or two such masking effects neither exceeding 1700 mm.

4.2.1.6 Blind spots caused by type approved rear-view mirrors may be disregarded if the design of these mirrors is such that they cannot be installed in any other way.

4.2.2 Mathematical determination of masking effects for binocular vision:

4.2.2.1 as an alternative to the procedure set out in clause 4.2.1 the acceptability of individual masking effects can be determined mathematically. The requirements of clauses 4.2.1.2, 4.2.1.3, 4.2.1.4, 4.2.1.5 and 4.2.1.6 shall apply in respect of the size, distribution and number of the masking effects;

4.2.2.2 for binocular vision with an inter-ocular distance of 65 mm, the masking effect expressed in mm is given by the formula;

$$v = \frac{(b - 65)}{a} \times 12000 + 65$$

in which:

a - is the distance in millimetres between the component obstructing vision and the reference point measured along the visual radius joining the reference point, the centre of the component and the perimeter of the semi-circle of vision;

b - is the width in millimeters of the component obstructing vision measured horizontally and perpendicular to the visual radius.

4.3 The test methods referred to under clause 4.2 may be replaced by others if the latter can be shown to be equivalent.

#### 4.4 **Transparent area of the windscreen**

For the purpose of determining the masking effects in the sector of vision, the masking effects due to the frame of the windscreen and to any other obstacle may, in accordance with the provisions of 4.2.1.4, be considered as a single effect provided that the distance between the outermost points of the masking effect does not exceed 700 mm.

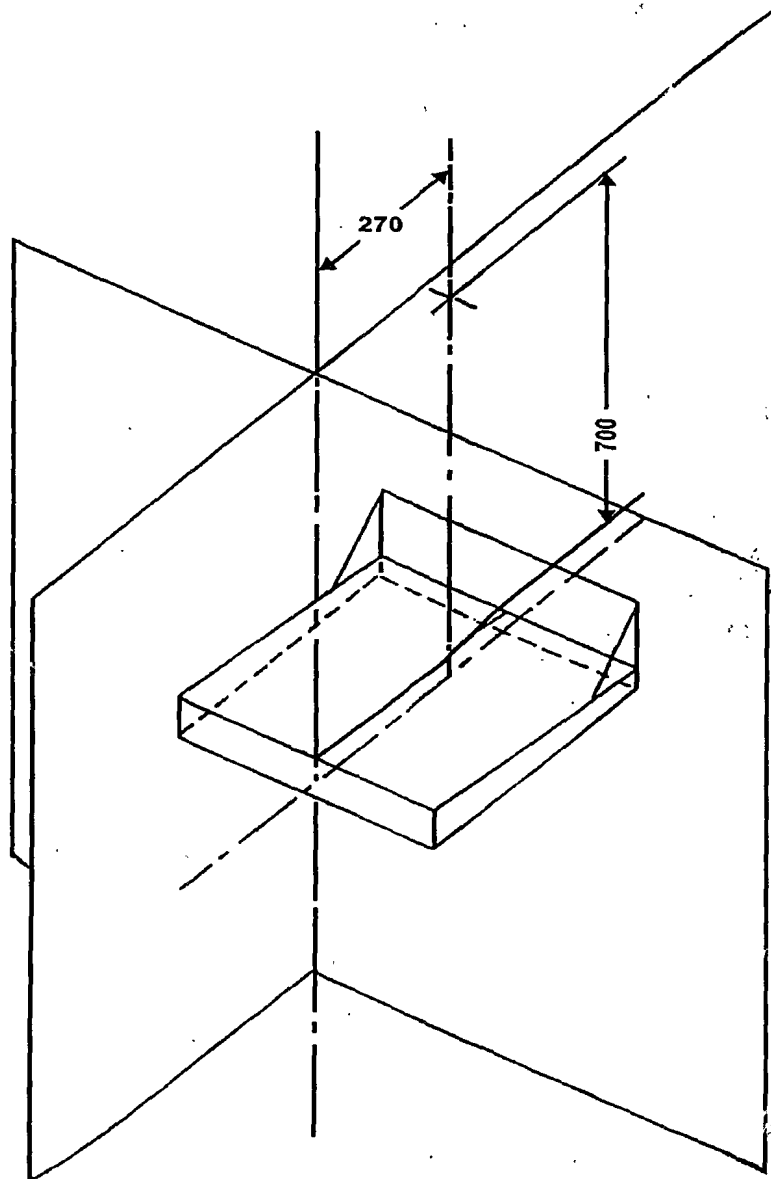

Dimensions are in mm

**Figure 1**  
**Reference Point**

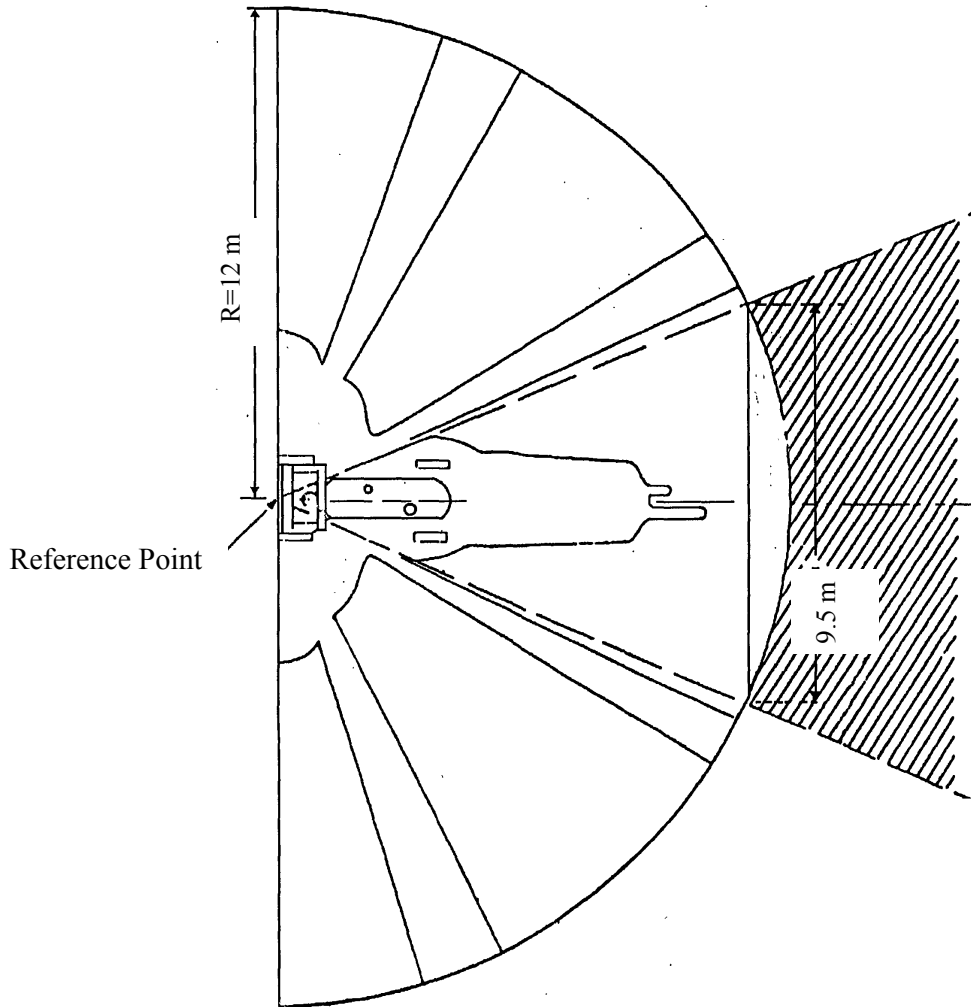

**Figure 2**  
**Semi-circle of Vision**



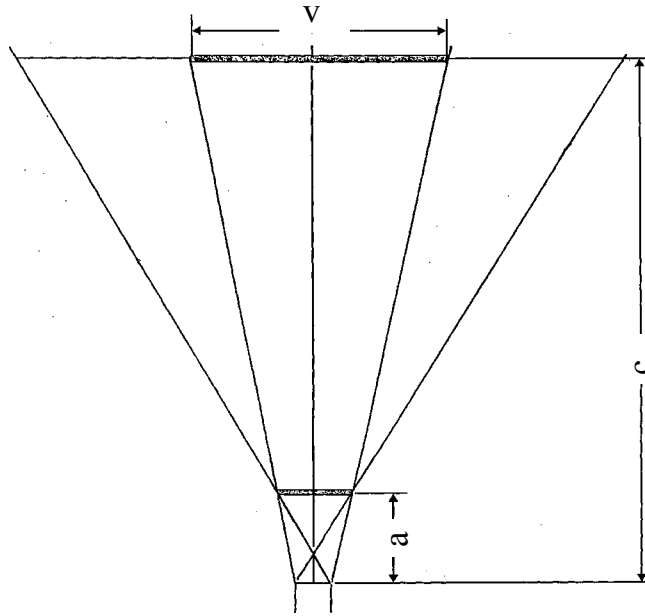

$$\frac{\frac{v}{2} - \frac{s}{2}}{c} = \frac{\frac{b}{2} - \frac{s}{2}}{a}$$

$$v = \frac{b - 65}{a} \cdot 12000 + 65$$

Figure 3

Determination of Masking Effects

**ANNEX I**  
(See Introduction)

**COMMITTEE COMPOSITION \***  
**Automotive Industry Standards Committee**

<b>Chairman</b>	
Shri Shrikant R. Marathe	Director The Automotive Research Association of India, Pune
<b>Members</b>	<b>Representing</b>
Representative from	Ministry of Shipping, Road Transport & Highways (Dept. of Road Transport & Highways), New Delhi
Representative from	Ministry of Heavy Industries & Public Enterprises (Department of Heavy Industry), New Delhi
Shri S. M. Ahuja	Office of the Development Commissioner, Small Scale Industries, Ministry of Small Scale Industries, New Delhi
Shri Rakesh Kumar	Bureau of Indian Standards, New Delhi
Director Shri D. P. Saste (Alternate)	Central Institute of Road Transport, Pune
Dr. M. O. Garg	Indian Institute of Petroleum, Dehra Dun
Dr. C. L. Dhamejani	Vehicles Research & Development Establishment, Ahmednagar
Representatives from	Society of Indian Automobile Manufacturers
Shri T.C. Gopalan	Tractor Manufacturers Association, New Delhi
Shri K.N.D. Nambudiripad	Automotive Components Manufacturers Association of India, New Delhi
Shri Arvind Gupta	Automotive Components Manufacturers Association of India, New Delhi

Member Secretary  
Mrs. Rashmi Urdhwareshe  
Deputy Director  
The Automotive Research Association of India, Pune

\* At the time of approval of this Automotive Industry Standard (AIS)