

SAFETY STANDARDS

No. 15.1

[Central Motor Vehicle Rules, 1989 Notification S.O. No. 873 (E)
dtd. 15.12.1997, item No. 20, of Ministry of SurfaceTransport].

**Lighting, Signalling & Indicating Systems on all Motor Vehicles,
other than Three Wheelers with Engine Capacity less than 500cc
and Motor Cycles and Tractors**

PUBLISHED BY
THE AUTOMOTIVE RESEARCH ASSOCIATION OF INDIA
P. B. NO. 832, PUNE 411 004

ON BEHALF OF:
DEPT. OF INDUSTRY
GOVERNMENT OF INDIA

AND

MINISTRY OF SURFACE TRANSPORT
GOVERNMENT OF INDIA

INTRODUCTION

(1986)

The question of prescribing Safety and Pollution Standards for automotive vehicles has been engaging the attention of the Government of India, Automotive Industry and Consumers. On pursuance of this objective Ministry of Industry, formed a committee to frame the safety standards and pollution standards. The Committee during its tenure formulated 36 safety standards.

On the completion of the tenure of the Committee, the work of framing of safety standards has been entrusted to Automotive Research Association of India under a project entitled 'Formulation of Safety Standards for Automotives'.

These safety standards, exclusively, have drawn material from Federal Motor Vehicle Safety Standards, Australian Design rules, EEC regulations and Indian standards.

These Standards are now under wide circulation as a preliminary to be converted into Indian Standards and will then be identified by an IS Number.

These Standards are likely to become mandatory and take effect after the Government's regulation.

(1993)

This safety standard is modified based on the discussion held till date with various organisations concerned in executing and implementing the same to bring in line with the current trends and requirements.

This standard has become mandatory under Rule No. 124 of CMV (A) R 1993 and takes effect from the Government's notification No. S. O. No. 201 (E) dtd. 26.3.93 by the Ministry of Surface Transport, Government of India.

(1998)

This safety standard is amended to include the amendments as recommended in part I of the recommendations of technical subcommittee set up to identify the changes in CMVR which have a technical bearing. This revised standard described as safety standard 15.1 supersedes all previous versions and is published by the Automotive Research Association of India. This standard takes effect from the Government of India notification S.O.No. 873 (E) dtd. 15.12.1997 issued by Ministry of Surface Transport (MOST).

ARAI desires to call attention to the fact that this safety standard does not purport to include all the necessary provisions of a contract.

Lighting, Signalling and Indicating Systems on all Motor Vehicles, other than Three Wheelers with Engine Capacity less than 500cc and motorcycles and Tractors

1.0 Scope

This standard lays down the requirements of lighting, signalling and indicating systems.

2.0 Purpose

This standard is intended to provide safety requirements of lighting, signalling and indicating systems for the safe operation of motor vehicles.

3.0 Application

This standard applies to passenger cars, multipurpose passenger vehicles, trucks, buses, trailers and to lamps, reflective devices and associated equipments. This standard will not apply to special purpose vehicles like combat vehicles.

4.0 Definitions

4.1 Lamp - A light source, which may be combined integrally with an optical system that directs and distributes light.

4.2 Light - An assembly device of the light source, an illuminated area and housing, a compartment into which the light source and optical system are fitted.

4.3 Headlight - A lighting device providing an upper and/or a lower beam used for providing illumination forward of vehicle.

4.4 Driving beam or upper beam or higher beam - Vehicle light intended to illuminate the road over a great distance ahead of the vehicle.

4.5 Meeting beam or lower beam or low beam - Beam illuminating only a specified limited part of the road, in order to reduce the dazzle for an observer approaching ahead of the vehicle.

4.6 Fog light - Vehicle light enabling the road to be effectively illuminated in fog, snow fall, rain storms or dust clouds.

4.7 Direction indicator or turn signal light - Lights used by the vehicle both during day and night by way of flashing for signalling with an intention to change direction to the right or to the left. The light shall be amber in colour.

4.8 Stop light - Brake operated signalling rear light on a vehicle, intended to give warning of the slowing down or the stopping of the vehicle. The light shall be red in colour.

4.9 Rear Number plate light - Light intended to illuminate the rear number plate. The light shall be white in colour.

4.10 Tail light - Red light emitted by a lighting device indicating the presence of a vehicle when seen from the rear and intended to show the width of the vehicle.

4.11 Flash - A cycle of activation and deactivation of a lamp by automatic means continuing until stopped either automatically or manually.

4.12 Emergency warning light - Roof mounted device for use on authorised emergency vehicles such as Police vehicles (flying squads), hospital ambulances, fire brigade vehicles and aerodrome vehicles.

4.13 Reversing light - A device used to provide a warning signal to pedestrians and other drivers, when the vehicle is reversing or is about to reverse. The light shall be white in colour.

4.14 Parking light - Light emitted by a lighting device indicating the presence of a vehicle as parked. The colour of the parking light shall be red for rear application and shall be amber or yellow or white for front application.

5.0 Design requirements

5.1 Each vehicle shall be equipped with the number of lights, reflective devices and associated equipment specified in Table 2 as applicable. This table indicates the application of illuminating devices, to passenger vehicles, trucks and trailers, buses and passenger cars.

5.2 The position of headlights on the vehicle shall be as per Rule No. 105 (3) of CMVR

5.3 The turn signal operating unit on each passenger vehicle, truck and bus shall be self-cancelling by steering wheel rotation and capable of cancellation by manual override also.

5.4 The lamp to be used for Photometric test of the headlights, tail lights, etc. shall conform to their standards. Where the luminous outputs of the lamps for the measurement are different from those specified in this standard, the measurement taken shall be proportionately corrected.

5.5 The materials used in the construction of automobile lighting devices shall be of such quality, type, design and construction that will provide adequate protection, in normal use, against mechanical and electrical failures and shall withstand the effects of changing weather conditions, water or excessive dampness, corrosion, thinner, dust,

steam, oil, high temperature, or any other deleterious influence to which they will be exposed under the conditions of their normal use.

5.6 Lighting and signalling devices shall be designed and constructed such that in normal use, their performance is reliable and that general maintenance including cleaning, replacement of lamps and accessories, where applicable, may be done without damage to the device.

5.7 The lamps used for headlight luminous and reflective devices shall be free from defects detrimental to service.

5.8 Each stop lamp on a passenger car and on multipurpose passenger vehicle, truck, trailer or bus shall have an effective rear projected luminous area not less than 22.5 sq.cms. in the intended direction. If multiple compartment lamps or multiple lamps are used, the effective rear projected luminous area of each compartment or lamp shall be not less than 22.5 sq.cms. However, the photometric requirements may be met by a combination of compartments or lamps.

5.9 Each turn signal lamp on a passenger car and on a multipurpose passenger vehicle, truck, trailer or bus less than 2 mtrs in overall width shall have effective projected luminous area not less than 22.5 sq.cms. If multiple compartment or multipurpose lamps are used, the effective projected luminous area in intended direction of each compartment or lamp shall be not less than 22.5 sq.cms. However, the Photometric requirements may be met by a combination of compartments or lamps. Each such lamp on a multipurpose passenger vehicle, truck trailer or bus of 2 mtrs. or more in overall width shall have effective Projected luminous area not less than 60 sq.crnns.

5.10 Variable load turn signal flashers shall comply with voltage drop with the maximum design load connected and shall comply with starting time, flash rate, and percent current "on" time requirements both with the minimum and with the maximum design load connected.

5.11 A tail light, parking light, Stop light or turn signal light shall meet the sum of candlepower measured at the test points specified for each group listed in table 8 and table 11.

5.12 Plastic materials used for optical parts such as lenses and reflectors shall also conform to test requirements to Appendix-B, clause 11.0.

5.13 The practice for installation of stop, tail and turn signal lights for automobiles shall be guided by the principles as laid down in Appendix-C.

6.0 Applicable Tests

The applicable tests to the lighting, signalling and indicating devices are shown in the table 1.

7.0 Test requirements of lighting, Signalling and Indicating Systems

Note: Explanation of Photometric Test points:

The test is made with sample unit located as if it were mounted on the vehicle. In defining angles or distances the focal point of the reflector shall be taken as the light source centre.

In locating the test points, the following symbols shall apply:

V : Is the line on a vertical test screen formed by the intersection of a vertical plane, perpendicular to the test screen, passing through the light source centre.

H : Is the line on a vertical test screen formed by the intersection of a horizontal plane, perpendicular to the test screen, passing through the light source centre.

H-V : Is the point of intersection of the lines H & V.
The other points on the screen are designated by similar symbols to indicate the number of degrees of arc (alternatively the distance in millimeters) above or below H and the number of degrees of arc (alternatively the distance in millimetres) to the left or right of V when the screen is viewed from the position of the light source. For example, 1/2D- 5R is a point 1/2° below the horizontal and 5° to the right of the vertical. Similarly 250U-1500L is a point 250 mm above the horizontal and 1500 mm left of the vertical.

The formula for the interconversion of the values in the units of 'lux' and 'candela' shall be as follows

$$Cd = LR^2$$

where

Cd = Luminance in candela,

L = Illumination in lux, and

R = Distance in metres between the screen and the source.

7.1 Test Requirements of Head Lights

7.1.1 Photometric requirements General - The lamps to be used for photometric test of headlight shall conform to specific standards. The filament lamp outputs are measured for all types of headlights at a voltage rating of 12 volts as specified in table 4 & 6. Photometric test points are located on a vertical test screen where the vertical and the horizontal intersecting points are located.

7.1.1.1 Anglo American Beam

The main beam of the unit shall be aimed visually so that the geometric centre of the zone of highest intensity is $1/2^\circ$ below the point H-V. The measurement of luminous intensity will be taken at test points described by Table 5 with the lamp output adjusted to values specified in Table 4. The test screen shall be placed at a distance of 25 metres at which distance a receptor subtending an angle not greater than 16 minutes shall be used. The beam should conform to values specified in Table 5.

7.1.1.2 European Asymmetrical Beam

The beam shall be aimed and tested as per Table 7. The measurement of luminous intensity will be taken at test points described by Table 7, with the lamp output adjusted to values specified in Table 6. The values shall be within the specified values of maximum and minimum as indicated in Table 7.

7.1.2 The headlight shall be tested for the tests indicated in table 1 according to the relevant test procedure laid down in Appendix-A and shall meet the relevant requirements of Appendix-B.

7.2 Test Requirements of Fog Light

The fog light shall be tested for the tests indicated in table 1 according to the relevant test procedure laid down in Appendix-A and shall meet the relevant requirements of Appendix-B.

7.3 Test Requirements of Licence plate Light

The licence plate light shall be tested for the tests indicated in table 1 according to the relevant test procedure laid down in Appendix-A and shall meet the relevant requirements of Appendix-B.

7.4 Test Requirements of Reversing Light

The Reversing light shall be tested for the tests indicated in table 1 according to the relevant test procedure laid down in Appendix-A and shall meet the relevant requirements of Appendix-B.

7.5 Test Requirements of parking lights, stop lights and direction indicators

The parking light, stop lights and director indicators shall be tested for the tests indicated in table 1 according to the relevant test procedure laid down in Appendix A and shall meet the relevant requirements of Appendix-B.

APPENDIX - A

TEST PROCEDURES

1.0 Photometric Test

The Photometric measurement shall be made at a distance between the light source and the point of measurement specified for the lighting device.

1.1 Testing procedure for head lights

The headlight shall be mounted on the goniometer with a suitable mounting plate. The power supply shall be connected to the main beam terminals of the headlight under test. The lamp is supplied with the appropriate voltage and current required for the lumen output required for the test as per Tables 4 and 6. All photometric readings shall be taken after the lamp has been lit for 10 minutes under the same condition.

The distance between the source and the photocell shall be 25 metres. The hot spot of the main beam shall be aligned to give maximum reading on the luxmeter. Then both the goniometer scales shall be set to the readings corresponding to the specified main beam position for Anglo American Beam ($1/2^\circ$ below H-V line) and for European Asymmetrical Beam (34' Below H-V line figure-2).

1.2 Testing procedure for parking lights stop lights and direction indicators

Apparatus - A suitable apparatus for marking photometric measurements of luminous intensity of these lighting and signalling equipment is shown in fig. 9. The photometer is based on the principle that the screen placed in the focal plane of the collimating lens will show on a reduced scale, the appearance at a great distance of the cross-section of the beam of light emitted. Further details of the photometer are as follows :

- (a) **Collimating lens** - This may be a simple lens, but the focal length should be not less than six times the diameter of the lens. The collimating lens diameter shall be at least equal to the greatest width of the lens of the tall-light under test.
- (b) **Screen** - The aperture in screen should be circular and should subtend an angle not greater than 1 degree at the collimating lens. The screen should be placed at the focal distance of the collimating lens.
- (c) **Photo electric cell** - This should preferably be of the photoemissive type, the output of which is fed into a suitable measuring device. The photo electric cell should be adequately colour corrected.

Procedure - In order to reduce errors resulting from inter-reflections between the collimating lens and the unit under test, the latter should be at a distance of not less than 30 cm from the collimating lens.

Calibration of the apparatus is carried out by substituting a standard light source for the test piece. The test piece is mounted on a tilting support so that its centre remains in a constant position and the required angles of view are obtained by tilting the test piece and so altering the direction of view.

The photometric readings are taken by swivelling the goniometer to the required degree of turning as indicated in the Table 8 for Parking lights, stop fights and table 11 for direction indicators.

1.3 Testing procedure for Fog Lights

The Illumination produced by the fog light shall be determined by means of a vertical screen set up 25 metres forward of the lens of the fog light (see fig. 8). In the case of type of construction other than a sealed beam type, a colourless bulb standard (reference) lamp of the type specified by the manufacturer shall be used. It shall be supplied with electric current at a voltage such that it produces the light flux prescribed for the tests corresponding to its type.

The fog light shall produce on the screen over a width of not less than 2.25 meters on both sides of the line V V as symmetrical cut off approximately sufficiently close to the horizontal to enable adjustment to be performed with its aid.

The fog light shall be so directed that the cut off on the screen is 500mm below the line HH.

When so adjusted, the fog light shall meet the requirements set out in table 9.

1.4 Testing procedure of Reversing Lights

Photometric measurements shall be made with a photometer or a luxmeter, keeping the photocell at least 3 metres from the lamp.

The lamp shall be mounted on a goniometer which is capable of giving minimum 180° rotation to the lamp in the horizontal plane and $\pm 20^\circ$ movement in the vertical plane from the axis of reference. The turn point shall be the optic centre of the lamp. The photocell or other similar transducer shall be mounted at the same height as the optic centre of the reversing light.

The light from a single light, when used in a two light system, shall meet the photometric requirements shown in Table 10.

When only one reversing light is used it shall meet the photometric requirements of table 10.

When two lights of the same or symmetrically opposite design are used, the reading along the vertical axis and the average of the readings for the same angle left and right of vertical for one lamp shall be used to determine compliance with the requirements of Table 10. If two lamps of differing designs are used, they shall be tested individually and the values added to determine that the combined units meet twice the candle power requirements.

When photometric measurements are taken, stray reflections shall be avoided by appropriate masking.

The direction $H=0^\circ$ and $V=0^\circ$ corresponds to the axis of reference. On the vehicle it is horizontal and parallel to the median longitudinal plane of the vehicle and oriented in the required direction of visibility. It passes through the centre of reference. The values shown in the Table 10, give, for the various direction of measurement the minimum intensity in candela (Cd).

The intensity requirements for a particular direction of observation shall be satisfied if the required intensity is obtained in a direction deviating by not more than one quarter of a degree from the direction of observation. The intensity along the axis of reference shall be not less than 80 candelas. The intensity of light emitted in all directions in which the light can be observed shall not exceed :

- (i) 300 candelas in directions in or above the horizontal plane.
- (ii) 600 candelas in directions below the horizontal plane.

1.5 Testing procedure of Licence Plate Light

All luminance measurements shall be made on a rectangular test plate of a clean white blotting paper mounted on the number plate holder in the position of the location taken by the number plate. The location of the test plate shall be 1.6 mm in front of the face of the number plate holder. The test points shall be located on the face of the test plate as given in Fig. 3. The measurements shall be taken in a darkened surrounding. This condition shall remain constant throughout the complete series of measurement.

2.0 Colorimetric test

The lighting devices and the reflecting devices shall be tested to check the colour of the light from the device for compliance with the colour specifications. The devices shall be

operated at design voltages. The components (bulbs, caps, lenses and the like) shall be tested in a fixture of manner simulating the intended application.

2.1 Visual method

In this method, the colour of the light from the device under test is compared visually with the colour of the light from a standard source. The standard source may consist of a filter or limit glass.

The standard shall be as close as possible to the limits listed in the definition.

The colour of the filter is determined spectrophotometrically. The standard source filter shall be certified for the particular colour and chromaticity coordinates by authorised national/international laboratory.

Red - Red shall not be acceptable if it is less saturated (paler), yellower or bluer than the limit standards.

Amber - Amber shall not be acceptable if it is less saturated (paler), greener or redder than the limit standards.

White - White shall not be acceptable if its colour differs materially from that of CIE source A (fig. 1).

Green - Green shall not be acceptable if it is less saturated (paler), yellower or bluer than the limit standards.

Blue - Blue shall not be acceptable if it is less saturated (paler), greener or redder than the limit standards.

In marking visual appraisals, the light from the device illuminates a portion of the comparator field. The standard source illuminates an immediately adjacent field portion of approximately equivalent area. It is preferable that standard field should surround the comparator field or vice-versa.

The location of the standard source and the test sample shall be adjusted so that comparator fields have equal and uniform luminance (brightness). The test equipment shall be so arranged that light is brought into the comparator field from the full aperture of the device or the component (Table 3).

2.2 Spectro radiometric or spectrophotometric method

The chromaticity co-ordinates may be computed from the spectral energy distribution curve. This shall be regarded as a referee approach rather than the commonly used method.

3.0 Vibration test

The test specimen mounted on a suitable support shall be rigidly fixed on a suitable vibrating machine constructed to produce simple harmonic function (a total amplitude of 1.5 mm) and shall be subjected to vibration through a frequency range of 10-55-10 Hz in a period of 1 minute with continuously varying frequencies. The vibration shall be applied for not less than 1 hour in the directions of each of the 3 major axes of the light. At the end of the vibration test, the test specimen shall be examined.

4.0 Test for resistance to oil

The outer surface of the lens of the sample unit shall be lightly wiped with a cotton cloth soaked in a mixture of petrol and benzol (90:10). After 5 minutes, the surface shall be inspected.

5.0 Corrosion Resistance Test

Apparatus : Salt Spray Chamber

The chamber for this test shall be so constructed that the salt spray is produced in the lower part of the chamber, in the upper part of which the parts to be exposed are suspended.

The construction of the ceiling walls and other parts of the chamber shall be such that no condensate can drip on the test specimen. The spray shall be produced by an atomizer employing compressed air free from all impurities.

In general, a salt spray chamber shown in fig. 5 with a spraying arrangement as shown in fig. 6 and complying with the following requirements would be suitable.

- (a) The cabinet shall approximately be of the dimensions shown, and the cabinet and its internal fittings shall be made of monel metal or other suitable material. A shelf capable of being fitted in the upper or lower part of the cabinet shall be provided.
- (b) The air used for atomizing the salt solution shall be clean. It shall be possible to adjust the pressure by a relief valve or by the pressure outlet of the blower.
- (c) It shall be possible to control the amount of spray by adjusting the position of the lower nozzle C by unscrewing the bottom locknut B. The diameter of nozzle shall be 1.5 mm. A tap and second branch in the air-line shall be available for agitating the salt solution as required.
- (d) The spraying apparatus shall be capable of atomizing not less than 1450 ml salt solution per hour. The quantity of solution sprayed per cubic metre capacity of the chamber shall be approximately 175 ml per minute.

- (e) A container filled with cotton wool shall be provided as shown in fig. 5. It acts as breather and provides an outlet for the air which is constantly being pumped into the chamber the cotton wool acting as a filter and preventing salt mist from being discharged into the atmosphere.

Procedure :

The nozzle for atomizing the salt solution shall be adjusted for maximum amount of spray.

The pressure of the solution shall be maintained between 29 and 33 kPa. The test piece shall be sprayed in the chamber with 5% solution of sodium chloride in water at the standard temperature of $27 \pm 2^\circ \text{C}$ for 50 hours consisting of two periods, each period being of 24 hours of spraying and one hour of draining. The pH of the salt solution shall be such that the collected solution will be in the pH range of 6.5 to 7.2.

6.0 Dust test for Seals & Gaskets

A sample unit with any drain hole closed shall be mounted in its normal operating position 150 mm from the wall in a box measuring 900 mm in all directions, containing 5 kg. of fine powdered cement. At intervals of 15 minutes this dust shall be agitated by compressed air of fan blower by projecting blasts of air for a two second period in downward direction into the dust in such a way that the dust shall be completely and uniformly diffused throughout the entire cube. The dust is then allowed to settle. In the meantime, the lamp is operated at the rated voltage continuously with an operating cycle of 30 minutes (15 min. lighting and 15 min. off). This test shall be continued for 5 hrs.

7.0 Moisture Test for adequate drainage

A sample unit shall be mounted in its normal operating position with all drain holes open and subjected to a precipitation of 2.5 mm of water per minute delivered at an angle of 45 degrees from a nozzle with a solid cone spray. The rate of water spray shall be measured by the rise of water in small straight sided pan placed horizontally and completely within the area covered by the water spray. During the moisture test, the unit shall revolve about its vertical axis at a rate of 4 rev/min. This test shall be continued for 12 hours. The water be then be turned off and the unit permitted to drain for 1 hour.

8.0 Heat Resistance Test

A filament lamp of same wattage as used for photometric tests which has been cleaned by wiping and by operating it outside the unit for 5 minutes shall be fitted to a sample unit without the filament lamp envelope being touched. The unit shall be run with the main beam filament at 7, 14 and 28 V for rated voltages of 6, 12 and 24 V respectively in its normal operating position for one hour in an ambient temperature of approximately 27°C .

9.0 Thermal shock resistance test

A sample unit shall be run for not less than 15 minutes with the filament at 7, 14 and 28 V for rated voltages of 6, 12 and 24 V respectively in its normal operating position in an ambient temperature of approximately 27°C. It shall then be disconnected and immediately plunged into water at 5°C below the ambient.

10.0 High voltage (flash) test

The test piece shall be isolated from the condensers, if any, and internally ground, and shall be subjected to flash test, with an alternating current of 500 Vrms at any convenient frequency between 40 and 60 Hz between the end of the terminals and the ground. During this test the lamps shall be removed.

11.0 Warpage test for units with plastic lenses

The sample unit shall be mounted in its normal position and operated as indicated below at design working voltage in an oven controlled at 50 ±1 deg.C for a duration of 1 hour.

Device	Steady Burn	5 On 5 Off	3 On 12 Off	Steady flash
Licence	X			
Tail, Fog tail Park	X			
Stop, Back up, Reversing, Rear cornering		X		
Cornering			X	
Direction Indicator				X
illuminating (Fog lamp, Driving lamps)	X			

(cycle time : minute)

12.0 Deterioration Test

The reflector of the lamp shall be placed in a circulating air hot chamber at 100°C for 1 hour. Then it shall be taken out and kept in the ambient temperature. After which, the following tests shall be carried out on each lamp independently :

- (1) Acid proof test : The reflector shall be immersed in a 1% sulfuric acid solution for 10 minutes.

- (2) Alkali proof test : The reflector shall be immersed in a 1% caustic potash solution for 10 minutes.
- (3) Salt solution proof test : Shall be immersed in a 3% sodium chloride solution for 10 minutes.

The test specified in this section shall not be carried out on the sealed beam type lamp. The tests shall be carried out in the solution at normal temperature instead of the product, on the test piece made under the same manufacturing condition as the products may be used for test.

13.0 Test for resistance in thinner

The outer surface of the lens of the sample unit shall be lightly wiped with a cotton cloth soaked in a commercially available thinner. After 5 minutes, the surface shall be inspected.

APPENDIX - B

TEST REQUIREMENTS

1.0 Photometric Test Requirements

1.1 Requirements for Headlights

The photometric test shall meet the requirements as specified in Table 5 and 7 when tested by the procedure as laid down in Appendix-A, clause 1.1 as applicable for the headlight pattern being tested. The photometric values of headlights shall be obtained with lamps with lumen outputs as specified in Appendix-A clause 1.1.

Note : If, however, lamps of other lumen values are used for this photometric test, the photometric values will have to be changed proportionately.

1.2 Requirements for parking lights, stop lights and direction indicators

The photometric test shall meet the requirements as specified in Table 8 and Table 11 when tested by the procedure as laid down in Appendix-A, clause 1.2 as applicable for the lighting unit under test.

1.3 Requirements for fog lights

The fog lights shall meet the photometric test requirements as specified in Table 9 when tested by the procedure as laid down in Appendix-A. clause 1.3.

1.4 Requirements of Reversing light

When Reversing lights are tested by the procedure laid down in Appendix-A, clause 1.4 the photometric requirements shall be met as in Table 10.

1.5 Requirements of Licence plate light

When tested by the test procedure laid down in Appendix-A, clause 1.5, the licence plate light shall meet the requirements as below :

- (a) The luminance in each of the test points (see fig. 3) shall not be less than 2.5 cd/m² and
- (b) The gradient of the luminance at any two test points shall not exceed twice the lowest luminance (C) per centimetre. In other words, if A and B are the luminance at two points, then

$$\frac{A-B}{\text{Distance in cm between A and B}} - < 2 C$$

2.0 Colorimetric Test Requirements

The colorimetric test shall meet the requirements as specified in Table 3, when tested by the procedure laid down in Appendix-A, clause 2.0.

3.0 Requirements of vibration test

When tested by the procedure laid down in Appendix-A, clause 3.0, the unit under test shall not show evidence of material defects, lens or reflector rotation, displacement or rupture of parts except filaments lamp failures.

4.0 Requirements of Resistance to oil test

When tested by the procedure laid down in Appendix-A. clause 4.0, the unit under test shall not show any visible change.

5.0 Corrosion Resistance test requirement

When tested by the procedure laid down in Appendix-A, clause 5.0, the unit under test shall not show a corrosion which shows a change of more than 10% variation in the photometric testing as tested in Appendix-A. clause 1.0.

6.0 Requirements of Dust Test for seals and gaskets

After the unit is tested by the procedure laid down in Appendix-A. clause 6.0 the exterior surface of the unit shall be cleaned and the photometric test repeated and if the maximum

intensity is within 10% of the maximum value found in the photometric test, it shall be considered adequately dust tight.

7.0 Requirements of Moisture test

When tested by the procedure laid down in Appendix-A, clause 7.0, the unit under test shall not accumulate moisture in excess of 2 ml.

8.0 Requirements of heat resistance test

When tested by procedure laid down in Appendix-A, clause 8.0, the unit under test shall not show deterioration of the reflecting surface.

9.0 Requirements of thermal shock resistance test

When tested by the procedure laid down in Appendix-A, clause 9.0, no cracking or fracture of the lens shall occur.

10.0 Requirements of high voltage or flash test

When tested by the procedure laid down in Appendix-A, clause 10.0, the test specimen shall satisfactorily withstand this test without arcing or puncture.

11.0 Requirements of warpage test

When tested by the procedure laid down in Appendix-A, clause 11.0, there shall be no evidence of excessive warpage of lenses which would affect the proper functioning of the unit.

12.0 Requirements of deterioration test

When tested by the procedure laid down in Appendix-A, clause 12.0, the reflectors reflecting surfaces shall show no significant changes.

13.0 Requirements of resistance to thinner test

When tested by the procedure laid down in Appendix-A, clause 13.0, the unit under test not show any visible change.

APPENDIX - C

CODE OF PRACTICE FOR INSTALLATION OF STOP, TAIL AND TURN SIGNAL LIGHTS

FOR AUTOMOBILES

1.0 General requirements

The lights shall be so fitted that under normal conditions of use they retain the characteristics laid down in this standard. In particular it shall not be possible for the adjustment of the lights to be inadvertently disturbed.

For all lights including those mounted on the side panels the reference axis of the light when fitted to the vehicle shall be parallel to the bearing plane of the vehicle on the road and in addition it shall be parallel to the median longitudinal plane of the vehicle. In each direction, a tolerance of $\pm 3^\circ$ shall be allowed.

In the absence of specific requirements, the height and alignment of the lights shall be checked with the unladen vehicle placed on a flat, horizontal surface.

In the absence of specific requirements, lights constituting a pair shall be fitted on the vehicle symmetrically in relation to the median longitudinal plane. They shall have substantially identical photometric requirements.

The maximum height above ground shall be measured from the highest point and the minimum height from the lowest point of the illuminating surface.

The colours of the light emitted shall be as follows

- (a) Stop Light : Red
- (b) Tail Light : Red
- (C) Turn Signal light : Amber

2.0 Stop Light

Each vehicle shall be provided with minimum 2 stop lights. No individual specification is being laid down for arrangement.

Width - The horizontal distance between the two stop lights shall be not less than 600 mm. This distance may be reduced to 400 mm, if the overall width of the vehicle is less than 1300 mm.

Height - The height above the ground shall be not less than 350 mm and not more than 1500 mm,. However, the height shall not be more than 2100 mm, if the shape of the body work makes it impossible to keep it within 1500 mm.

Location - The stop lights shall be installed at the rear of the vehicle.

Geometric visibility - The horizontal angles shall be 45° outwards and inwards. The vertical angle shall be 15° above and below the horizontal. The vertical angles below the horizontal may be reduced to 5° in the case of lights fitted at a height less than 750 mm above the ground.

Alignment - The alignment of the stop lights shall be towards the rear of the vehicle.

Stop light may be grouped with one or more rear lights, or combined with another light. However, it shall be reciprocally incorporated with the tail light or rear parking light only.

The stop light shall light up when service brake is applied.

3.0 Tail Lights

Every vehicle shall be provided with 2 tail lights. No Individual specification is being laid down for arrangement.

Width - The point on the illuminating surface farthest from the vehicle's median longitudinal plane shall be not more than 400 mm from the extreme outer edge of the vehicle.

The distance between the inner edges of the two illuminating surfaces shall be not less than 600 mm. This distance may be reduced to 400 mm, where the overall width of the vehicle is less than 1300 mm.

Height - The height of tail lights above the ground shall be not less than 350 mm and not more than 1000 mm. However, the distance shall not be more than 2100 mm, if the shape of the body work makes it impossible to keep it within 1000 mm.

Location - The tail lights shall be installed at the rear of the vehicle.

Geometric visibility - The horizontal angle for the two tail lights shall be either 45° inward and 80° outward. The vertical angles shall be 15° above and below in the case of lights fitted at a height less than 1000 mm above the ground.

Tail lights may be grouped with any other rear light, or combined with the rear number plate light and reciprocally incorporated with the stop light or rear fog light or the rear parking light.

4.0 Turn Signal Lights

The assembly of the turn signal light according to categories 1, 2 and 5, on the vehicle shall constitute either of the following arrangement (see fig. 10).* *

(a) Arrangement A - For motor vehicles, and

(b) Arrangement B - for trailers

Arrangement A shall be as given below

- :(a) Two front turn signal lights (category 1)
 - ;(b) Two rear turn signal lights (category 2);
- and

(c) Two repeating turn signal lights, compulsory for heavy duty commercial vehicles and recommended for other vehicles (category 5).

* *The number of devices shall be such as to emit signals corresponding to one of the arrangement referred above.

* *Arrangement B shall consist of two rear turn signal lights (category 2).

Width - The edge of the illuminating surface of the turn signal light farthest from the median longitudinal plane of the vehicle shall not be more than 400 mm from the extreme outer edge of the vehicle. The distance between the inner edges of the two illuminating surface shall be not less than 600 mm. Where the vertical distance between the rear turn signal light and the corresponding tail light is not more than 300 mm the distance between the extreme outer edge of the vehicle and the outer edge of the rear turn signal light shall not exceed by more than 50 mm of the distance between the extreme outer edge of the corresponding tail light. For front turn signal light the illuminating surface shall be not less than 40 mm away from the illuminating surface of the dipped beam or front fog light, if any. A smaller distance shall be permitted if the luminous intensity in the reference axis of the turn signal light is equal to at least 400 cd.

Height - The height of the turn signal light above the ground shall be as given below:

- (a) Not less than 500 mm for category 5
- (b) Not less than 350 mm for categories 1 and 2;and
- (c) Not more than 1500 mm for all categories.

If the structure of the vehicle makes it impossible to keep to this figure, the highest point of the illuminating surface may be at 2300 mm in case of category 5 and at 2100 mm in the case of categories 1 and 2.

Length - The distance between the center of reference of the illuminating surface of the turn signal light (arrangement A) and the transverse plane which marks the forward boundary of the vehicles overall length, shall not exceed 1800 mm. If the structure of the vehicle makes it impossible to comply with the minimum angles of visibility, the distance may be increased to 2500 mm, if the vehicle is equipped in conformity with arrangement A.

Geometric visibility - The horizontal angles shall be as shown in fig. 10. The vertical angles shall be 15° above and below the horizontal. The vertical angle below the horizontal may be reduced to 5° in case of turn signal lights of arrangements A, if they are less than 750 mm above the ground.

Turn signal lights may be grouped with one or more lights, or combined with another light. However, they shall be but reciprocally incorporated with a parking light only. Turn signal lights shall switch on independent of the other lights. All turn signal lights on one side of the vehicle shall be switched on and off simultaneously by means of one control and must flash in phase.

**TABLE 1
TESTS APPLICABLE**

Ref. J App. A.	1.0 Photometry	2.0 Colorimetry	3.0 Vibration Test	4.0 Oil Resistance Test	5.0 Corrosion Resistance Test	6.0 Dust Test	7.0 Moisture Test	8.0 Heat Resistance Test	9.0 Thermal Shock Test	10.0 High Voltage Test	11.0 Warpage Test	12.0 Deterioration Test	13.0 Resistance to Thinner Test
Head Light	✓	✓	✓	✓	✓	✓	✓	✓	✓	✓		✓	✓
Fog Light	✓	✓	✓	✓	✓	✓	✓	✓	✓	✓		✓	✓
Rear Licence													
Plate Light	✓	✓	✓	✓	✓	✓	✓	✓	✓	✓		-	✓
Tail Light	✓	✓	✓	✓	✓	✓	✓	✓	✓	✓		p+	✓
Stop Light	✓	✓	✓	✓	✓	✓	✓	✓	✓	✓		p+	✓
Direction													
Indicator Light	✓	✓	✓	✓	✓	✓	✓	✓	✓	✓		p+	✓
Parking Light	✓	✓	✓	✓	✓	✓	✓	✓	✓	✓		p+	✓
Reversing Light	✓	✓	✓	✓	✓	✓	✓	✓	✓	✓		✓	✓

p+ : Applicable where reflectors are provided.
 p++ : Applicable where plastic lenses are provided

**TABLE 2
MANDATORY REQUIREMENTS OF ILLUMINATING DEVICES**

Type of Vehicle	Head light	Fog light	Rear licence plate light	Rever-sing light	Tail light	Stop light	Direction indicator light	Parking light
1. Passenger cars	*(2)	***(2)	*(1)	*At least one	*(2)	*(2)	*(4)	*(4)
2. Multipurpose passenger vehicle	*(2)	***(2)	*(1)	*At least one	*(2)	*(2)	*(4)	*(4)
3. Trucks / Tractors	*(2)	***(2)	*(1)	*At least one	*(2)	*(2)	*(4)	*(4)
4. Buses	*(2)	***(2)	*(1)	*At least one	*(2)	*(2)	*(4)	*(4)
5. Trailer	-	-	*(1)	*At least one	*(2)	*(2)	*(2)	-

* Mandatory device

** Mandatory in specified areas

Number in () indicate the number of illuminating and reflecting devices to be fitted on the vehicle.

**TABLE 3
RANGE OF CHROMATICITY**

Kind	Colour	Red	Amber	Yellow	White
	Chromaticity range →	$y \leq 0.335$ $z \leq 0.008$	$0.44 \geq y \geq 0.39$ $z \geq 0.007$	$y \geq 0.138 + 0.580x$ $y \leq 1.29x + 0.100$	$0.31 + 0.25x \geq y \geq 0.28 + 0.25x$ $0.50 \geq x \geq 0.41$
	Type ↓			$y \geq -x + 0.966$ $y \leq -x + 0.992$	
Head Light	-	-	-	-	0
Fog Light	-	-	-	0	0
Rear Licence plate light	-	-	-	-	0
Reversing Light	-	-	-	-	0
Tail Light	-	0	-	-	-
Stop Light	-	0	-	-	-
Turn signal light or Direction Indicator	Front use	-	0	-	-
	Side use	-	0	-	-
	Rear use	-	0	-	-
Parking light	Front use	-	0	0	0
	Rear use	0	-	-	-

Remark : x, y and z in the above table means the chromatic co-ordinates specified as in fig. 1.

TABLE 4
ANGLO AMERICAN BEAM-FILAMENT OUTPUTS FOR LUMINOUS INTENSITY TEST

<u>Filament Lamp 12V, 50/40W</u> (1)	<u>Light Flux</u> (2) Lumens
Driving beam filament	860
Passing beam filament	645

Note : The light flux values are generally those available at operating voltages in a moving vehicle.

TABLE 5
LUMINOUS INTENSITY VALUES

MAIN BEAM				DIPPED BEAM			
Test Points		Intensity Values		Test Points		Intensity Values	
V (1)	(H) (2)	Min (3) Candelas	Max (4) Candelas	V (5)	H (6)	Min. (7) Candelas	Max. (8) Candelas
2U	3L & 3R	800	-	10to90U	-	-	250*
1U	3L & 3R	2000	-	1-1/2 U	1Lto90L	-	1000
1/2D	V	25000	-	1 U	1Rto90R	-	800
1/2D	3L & 3R	10000	-	1/2 U	1L to 3L	-	2000
1/2D	6L & 6R	2500	-	1/2 U	1R to 90R	-	1000
1/2D	9L & 9R	800	-	1/2 D	1L to 90L	-	10000
1/2D	12L & 12R	600	-	1/2 D	2L	1800	-
2D	V	3000	-	1/2 D	1R to 90R	-	2000
2D	9L & 9R	1500	-	1 D	1R to 6R	500	-
3D	V	2500	-	1-1/2 D	2L	6000	-
3D	12L & 12R	400	-	1-1/2 D	9L	1000	-
4D	12L & 12R	-	5000	1-1/2 D	9R	500	-
				4 D	4L	-	16000

* - For the normally exposed surface of the lens

TABLE - 6
EUROPEAN BEAM - FILAMENT OUTPUTS LUMINOUS INTENSITY TEST

<u>Filament Lamp 12V, 45/40W</u>	<u>Light Flux</u>
(1)	(2)
Driving beam filament	700
Passing beam filament	450

Note : The light flux values are generally obtainable at the nominal volts and may be higher in operation on a vehicle.

TABLE - 6 A
EUROPEAN BEAM - FILAMENT OUTPUTS FOR LUMINOUS INTENSITY TEST

	<u>Consumption in Watts</u>	<u>Light flux in Lumens</u>
Passing filament	About 55	750
Driving filament	About 60	1250

Note : The light flux values are generally obtainable at the nominal volts and may be higher in operation on vehicle.

TABLE - 7
EUROPEAN ASYMMETRICAL BEAM - LUMINOUS INTENSITY VALUES

Driving Beam					Meeting Beam				
Test Point	Vertical Distance	Horizontal Distance	Intensity values		Test Point No.	Vertical Distance	Horizontal Distance	Intensity values	
			Min.	Max.				Min.	Max.
(1)	(2) mm.	(3) mm.	(4) Candelas	(5) Candelas	(6)	(7) mm.	(8) mm.	(9) Candelas	(10) Candelas
1	0	0	20000	-	B50R	250U	1500R	-	187.5
2	0	1125L to 1125R	10000	-	75L 50L	250D 375D	500L 750L	3750 3750	- -
3	0	1125L to 2250L	2500	-	25R 25L	750D 750D	3960R 3960L	937.5 937.5	- -
4	0	1125R to 2250R	2500		Any Point in Zone I	Below 750D	3960L to 3960R	-	12500
					Any Point in Zone II	See Fig.2	See Fig.2	Nil	Nil
					Any Point in Zone III	-do-	-do-	-	437.5
					Any Point in Zone IV	375D to 750D	2250L to 2250R	1250	-

TABLE 7 A
EUROPEAN ASYMMETRICAL BEAM-LUMINOUS INTENSITY VALUES
FOR HALOGEN 12 V, 60/55 W BULB

Driving Beam					Passing Beam					
Test Point	Vertical Dist. mm	Horizontal Dist. mm	<u>Intensity Value</u> Candela		Test Point	Vertical Dist. mm	Horizontal Dist. mm	<u>Intensity Value</u> Candela		
			Min.	Max.				Min.	Max.	
1	0	0	30,000	1,50,000	B50R	250U	1500R	---	250	
				OR						
				16 x intensity at 75 L	75L	250D	500L	7,500	---	
				whichever is less	50L	375D	750L	7,500	---	
					25R	750D	3960R	1,250	---	
				25L	750D	3960L	1,250	---		
2	0	1125 L to 1125 R	15,000	----	Any Point in	Below 750D	3960L to 3690R	---	2 x intensity at 50 L	
3	0	1125 L to 2250 L	3,750	----	Zone I Any Point in	---	----	---	437.5	
4	0	1125 R to 2250 R	3,750	----	Zone III Any Point in Zone IV	375D to 750D	2250L to 2250R	1875	---	

TABLE 8
LUMINOUS INTENSITY VALUES IN CANDELAS
FOR TAIL, PARKING AND STOP LIGHTS

<u>Test points</u>		<u>Tail Lights</u>		<u>Parking lights</u>				<u>Stop Lights</u>	
V	H	Min.	Max.	Front facing	Rear	Min.	Max.	Min.	Max.
				Min.	Max.	facing		Min.	Max.
				Min.	Max.	Min.	Max.		
(1)	(2)	(3)	(4)	(5)	(6)	(7)	(8)	(9)	(10)
15U	V	0.05	12	0.05	60	0.05	12	0.3	160
10U	5L	0.4	12	0.8	60	0.4	12	8.0	160
10U	5R	0.4	12	0.8	60	0.4	12	8.0	
160									
5U	20L	0.2	12	0.4	60	0.2	12	4.0	160
5U	20R	0.2	12	0.4	60	0.2	12	4.0	160
H	90L*	0.05	12	0.05	60	0.05	12	-	160
H	45L	-	12	-	60	-	12	0.3	160
H	10L	0.7	12	1.4	60	0.7	12	14.5	160
H	5L	1.8	12	3.6	60	1.8	12	35.0	160
H	V	2.0	12	4.0	60	2.0	12	40.0	160
H	5R	1.8	12	3.6	60	1.8	12	35.0	160
H	10R	0.7	12	1.4	60	0.7	12	14.5	160
H	45R	-	12	-	60	-	12	0.3	160
H	90R*	0.05	12	0.05	60	0.05	12	-	160
5D	20L	0.2	-	0.4	60	0.2	-	4.0	160
5D	20R	0.2	-	0.4	60	0.2	-	4.0	160
10D	5L	0.4	-	0.8	60	0.4	-	8.0	160
10D	5R	0.4	-	0.8	60	0.4	-	8.0	160
15D	V	0.05	-	0.05	60	0.05	-	0.3	160

* Where 'handed' tail-lights are tested, for example, lights which are made in pairs, one left-hand and one right-hand, then each light, as fitted to a vehicle, shall comply with these minimum and maximum intensities at 90° outboard but need only comply at 45° in board.

Ratio: The ratio of stop light intensity to tail-light intensity in combined units shall exceed 5 to 1 at the following test points

H-V, H-5L, H-5R, H-10L and H-10R.

TABLE 9

REQUIREMENTS FOR ILLUMINATION FOR FOG LIGHTS

Zone	Position on measuring screen, zone limit	Illumination required in lux
On the line HH between points hl & h2	225 cm (5° 15) on both sides of line V V	≥ 0.3
A	225 cm (5° 15) on both sides of the line V V & 75 cm (1° 72) above HH	≥ 0.15 and 1
B	1250 cm (26° 5) on both sides of the line V V & 150 cm (3° 44) above HH including HH (except zone A)	≤ 1
C	1250 cm (26° 5) on both sides of line V V & starting from 150 cm above HH	≤ 0.5
D	450 cm (10° 20) on both sides of line V V & comprised between the parallels to HH respectively situated 75 and 150 cm below HH	On each vertical line in this zone there shall be at least one point (a,b,c,) where the illumination is ≥ 1.5
E	From 450 cm (10° 20) to 1000 cm (21° 45) on both sides of zone D and comprised between the parallels to HH respectively situated 75 and 150 cm below HH.	On each vertical line in this zone there shall be atleast one point where the illumination is ≥ 0.5

Note: The illumination shall be measured either in white light or in coloured light as prescribed by the manufacturer for use of the fog light in normal service. No variation in illumination detrimental to satisfactory visibility shall exist in either of the zones B and C.

TABLE 10
PHOTOMETRIC MINIMUM CANDELA REQUIREMENTS FOR
REVERSING LIGHTS

Test point	45L	30L	10L	V	10R	30R	45R
10U	-	-	10	15	10	-	-
5U	15	-	20	25	20	-	15
H	15	25	50	80	50	25	15
5D	15	25	50	80	50	25	15

TABLE 11
LUMINOUS INTENSITY VALUES (IN CANDELAS)
FOR DIRECTION INDICATORS

<u>Test points</u>		<u>Front Facing</u>		<u>Rear Facing</u>	
V (1)	H (2)	Min. (3)	Max. (4)	Min. (5)	Max.* (6)
15 U	V	0.3	700	0.3	200
10 U	5 L	20.0	700	10.0	200
10 U	5 R	20.0	700	10.0	200
5 U	20 L	10.0	700	5.0	200
5 U	20 R	10.0	700	5.0	200
H	80 L	0.3	700	0.3	200
H	45 L	0.3	700	0.3	200
H	10 L	35.0	700	17.5	200
H	5 L	90.0	700	45.0	200
H	V	100.0**	700	50.0	200
H	5 R	90.0	700	45.0	200
H	10 R	35.0	700	17.5	200
H	45 R	0.3	700	0.3	200
H	80 R	0.3	700	0.3	200
5 D	20 L	10.0	700	5.0	200
5 D	20 R	10.0	700	5.0	200
10 D	5 L	20.0	700	10.0	200
10 D	5 R	20.0	700	10.0	200
15 D	V	0.3	700	0.3	200

* For side-mounted double-faced units, the maximum of 200 cd shall be increased to 400 cd.

** In order to comply with international recommendations, a minimum value of 100 candelas is required for front facing direction indicators at H-V. However, it is recommended that minimum value of 175 candelas should be aimed at and minimum values at other test points increased proportionately.

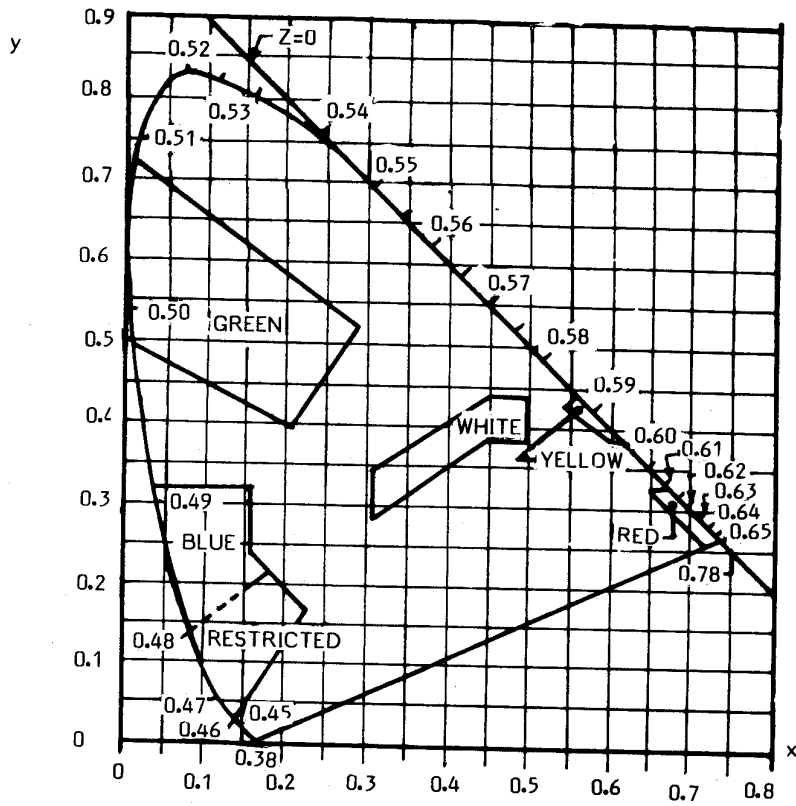

FIGURE 1 : COLORIMETRIC ZONES OF COLOUR TRIANGLE

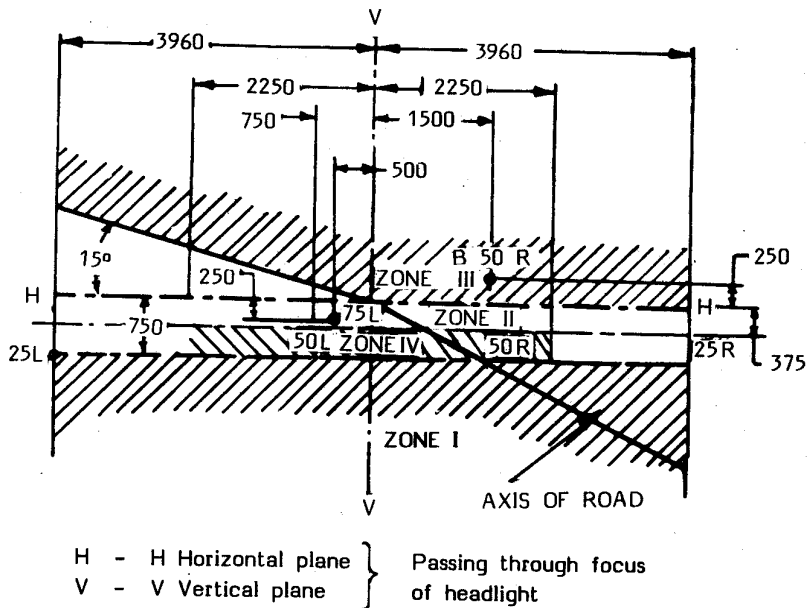
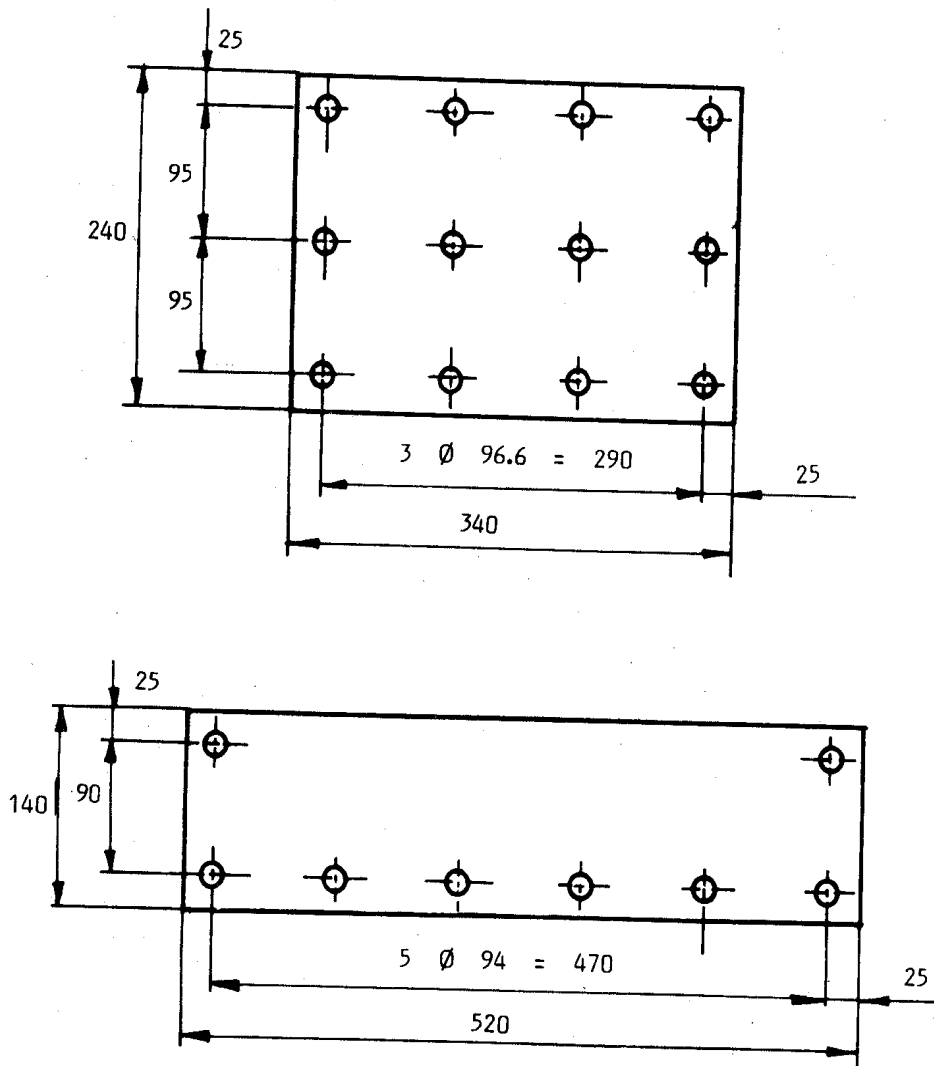

FIGURE 2 : TEST SCREEN (EUROPEAN ASYMETRICAL BEAM)

ALL DIMENSIONS IN MM.



TEST POINTS
FIGURE No. 3

NOTE : These dimensions do not indicate the actual size of the number plates to be used but are based on the dimensions recommended by ISO.

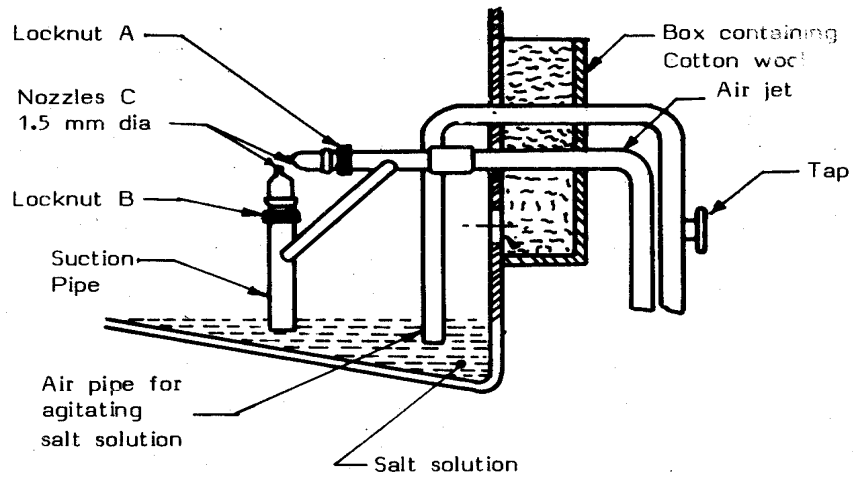
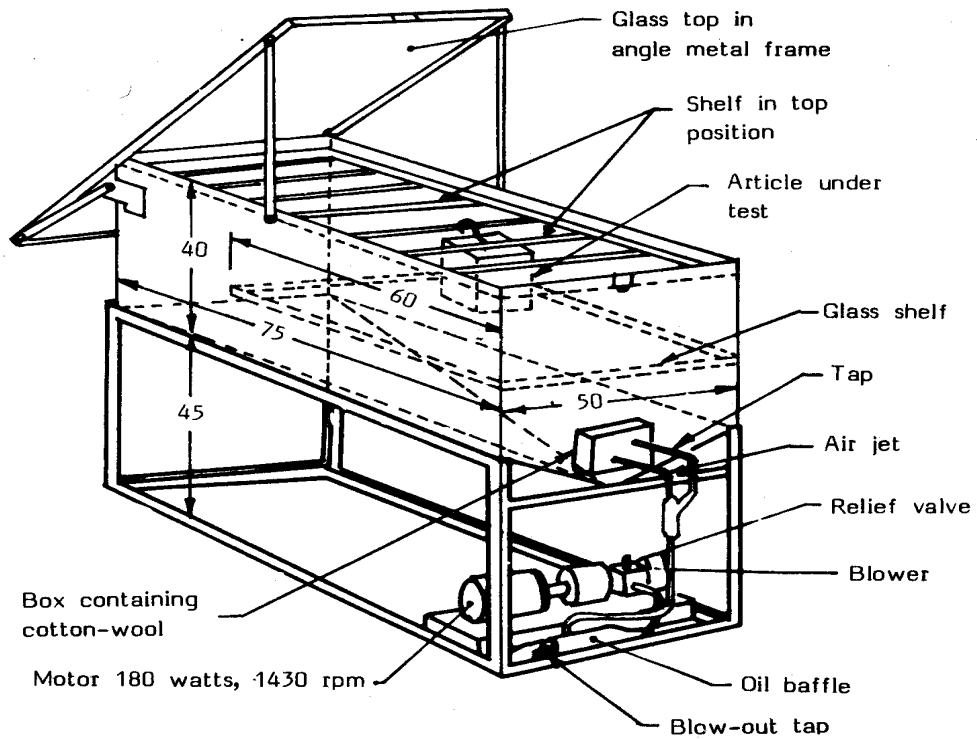

FIGURE No. 5
SALT SPRAY CHAMBER



DIMENSIONS IN CENTIMETRES

FIGURE No. 6
DETAILS OF SPRAYING ARRANGEMENT

ALL DIMENSIONS IN MM.

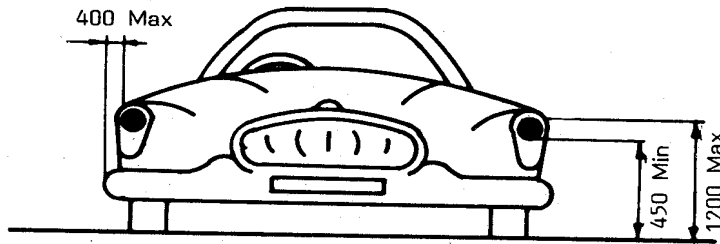

FIGURE No. 7
HEAD LIGHT

MEASURING SCREEN

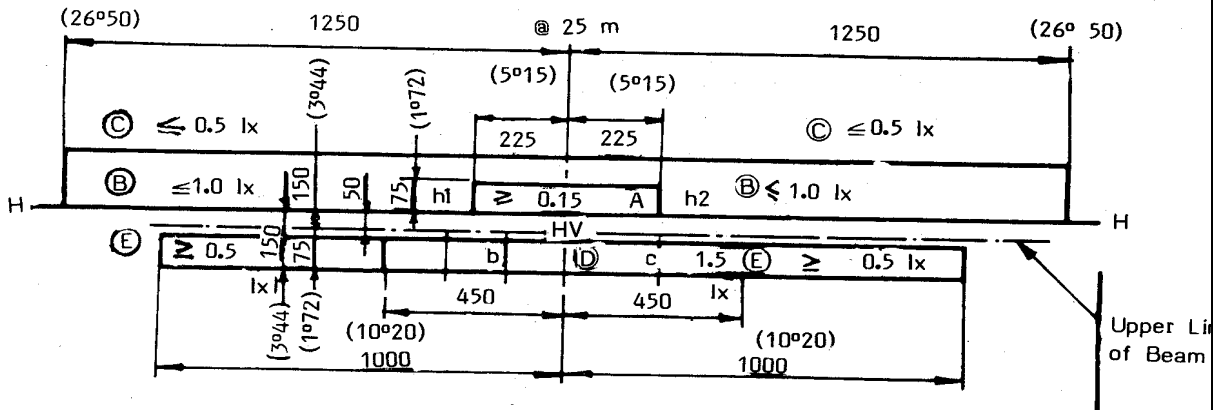

FIGURE No. 8

HV - Point of intersection of lines HH and VV

NOTE : The figures following the degree sign are one-hundredths of a degree.

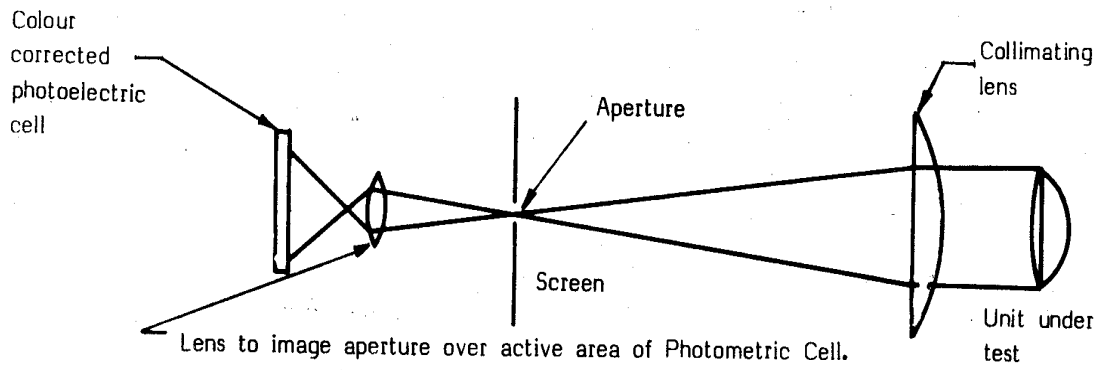

FIGURE 9

OPTICAL LAYOUT OF PHOTOMETER

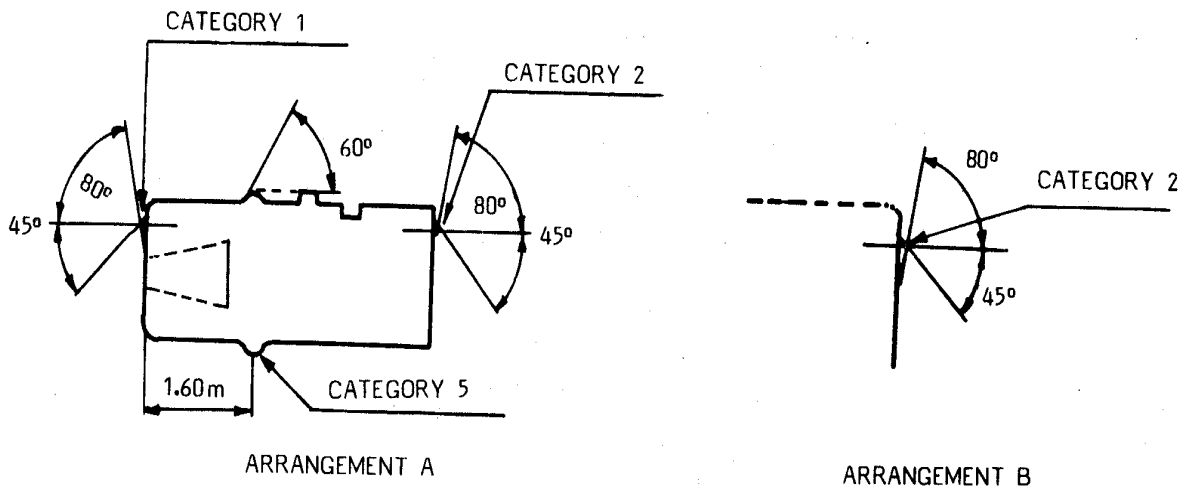

FIGURE 10

[ARRANGEMENT B SHALL CONSIST OF TWO REAR TURN SIGNAL LIGHTS (CATEGORY 2)]