

FINALIZED DRAFT

AUTOMOTIVE INDUSTRY STANDARD

**Performance Requirements of
Rear Marking Plates (Rear Warning
Triangles) for Automotive Vehicles,
Agricultural Tractors their Trailers and
Semi-Trailers**

INTRODUCTION

The Government of India felt the need for a permanent agency to expedite the publication of standards and development of test facilities in parallel when the work on the preparation of the standards is going on, as the development of improved safety critical parts can be undertaken only after the publication of the standard and commissioning of test facilities. To this end, the erstwhile Ministry of Surface Transport (MoST) has constituted a permanent Automotive Industry Standards Committee (AISC) vide order No.RT-11028/11/97-MVL dated September 15, 1997. The standards prepared by AISC will be approved by the permanent CMVR -Technical Standing Committee (CTSC). After approval, the Automotive Research Association of India, (ARAI), Pune, being the Secretariat of the AIS Committee, has published this standard. For better dissemination of this information ARAI may publish this document on their Web site.

The standard purports to rear marking plates used to increase the visibility of the rear of slow moving vehicles (SMV) which, by construction, can not travel faster than 40 km/h, agricultural tractors, their trailers and semi-trailers

Rain simulation test specified vide clause 1.4.3 in Annex-6 to be exempted during component approval till such time the test method and acceptance criteria are clarified.

While preparing this standard considerable assistance has been derived from following ECE regulation.

UN R 69 Addendum 69 - Revision 1 - Supplement 4 to the 01 series of amendments – Date of entry into force: 15 October 20008	Uniform provisions concerning the approval of rear marking plates for Slow-Moving Vehicles (By Construction) and their trailers
---	---

The AISC panel and the Automotive Industry Standards Committee (AISC) responsible for preparation of this standard are given in Annex 13 and Annex 14 respectively.

CONTENTS

Sr. No	Description	Page No
1.	Scope	
2.	Reference	
3.	Definitions	
4.	Technical information to be submitted by the manufacturer	
5.	Markings	
6.	General specifications	
7.	Special specification (tests)	
8.	Modifications and extension of approval of rear marking plate (Rear Warning Triangle)	
9.	Conformity of production	
ANNEXES		
Annex 1	The CIE co-ordinate system	
Annex 2	Test procedure	
Annex 3	Specifications of shape and dimensions - shape and dimensions of retro-reflective /fluorescent (class 1) or retro-reflective only (class 2) rear marking plates.	
Annex 4	Colorimetric specifications	
Annex 5	Photometric specifications	
Annex 6	Resistance to external agents	
Annex 7	Resistance to heat	
Annex 8	Rigidity of the plates	
Annex 9	Shape and dimension of rear marking plates (rear warning triangle) automotive vehicles, agricultural tractors, their trailers and semi-trailer	
Annex 10	Minimum requirements for conformity of production control procedures	
Annex 11	Minimum requirements for sampling by an inspector	

Note : Page Nos. will be corrected in the final print.

AIS-088 (Rev.1) Performance Requirements of Rear Marking Plates (Rear Warning Triangles) for Automotive Vehicles, Agricultural Tractors, their Trailers and Semi-Trailer

1. SCOPE

These provisions apply to the approval of rear marking plates used to increase the visibility of the rear of slow moving vehicles (SMV) which, by construction, can not travel faster than 40 km/h, agricultural tractors, their trailers and semi-trailers.

2. REFERENCES

- 2.1 The definitions of technical terms are those adopted by the International Commission on Illumination (CIE) - see Technical Report on Retro-reflection , CIE Publication No. 54.
- 2.2 AIS-030 (Rev.1) : Installation Requirements of Lighting and Light-Signalling Devices for Agricultural Tractors

3. DEFINITIONS

3.1 For the purpose of these provisions, the following definitions shall apply:

3.1.1 **"SMV Rear marking plate (rear warning triangle)"** a triangular plate with truncated corners with a characteristic pattern faced with retro-reflective and fluorescent material or devices (class 1); or with retro-reflective materials or devices only (class 2).

3.1.2 **"Sample unit"** a complete, finished plate ready to be mounted on a vehicle and representative of current production.

3.2 Retro-reflection

Reflection in which radiation is returned in directions close to the direction from which it came, this property being maintained even over wide variations of the direction of the incident radiation:

3.2.1 **"Retro-reflective material"** a surface or device from which, when directionally irradiated, a relatively large portion of the incident radiation is retro-reflected.

3.2.3 **"Retro-reflective device"** an assembly ready for use and comprising one or more retro-reflective optical units.

3.3 Geometric definitions (see Annex 1, Figure 1 and 2).

3.3.1 **"Reference center"** a point on or near a retro-reflective area which is designated to

be the center of the device for the purpose of specifying its performance.

- 3.3.2 "**Illumination axis**" a line segment from the reference center to the light source.
- 3.3.3 "**Observation axis**" a line segment from the reference center to the photometer head.
- 3.3.4 "**Observation angle (Symbol α)**" the angle between the illumination axis and the observation axis. The observation angle is always positive and, in the case of retro-reflection, is restricted to small angles.
Maximum range: $0 \leq \alpha \leq 80^\circ$.
- 3.3.5 "**Observation half-plane**" the half-plane which originates on the illumination axis and which contains the observation axis.
- 3.3.6 "**Reference axis**" a designated line segment originating on the reference center which is used to describe the angular position of the retro-reflective device.
- 3.3.7 "**Entrance angle (Symbol β)**" the angle from the illumination axis to the reference axis. The entrance angle is usually not larger than 90° but, for completeness, its full range is defined as $0 \leq \beta \leq 180^\circ$. In order to specify the orientation in full, this angle is characterized by two components, β_1 and β_3 .
- 3.3.8 "**First axis**" an axis through the reference center and perpendicular to the observation half-plane.
- 3.3.9 "**First component of the entrance angle (Symbol β_1)**" the angle from the illumination axis to the plane containing the reference axis and the first axis.
Range: $-180^\circ \leq \beta_1 \leq 180^\circ$.
- 3.3.10 "**Second component of the entrance angle (Symbol β_3)**" the angle from the plane containing the observation half-plane to the reference axis range: $-90 \leq \beta_3 \leq 90$.
- 3.3.11 "**Second axis**" an axis through the reference center and perpendicular to both the first axis and the reference axis. The positive direction of the second axis lies in the observation half-plane when $-90^\circ \leq \beta_1 \leq 90^\circ$ as shown in annex 1, figure 1.
- 3.3.11 "**Angle of Rotation ε** " angle through which the sample is turned about its vertical axis from any arbitrarily established position counter clockwise ($+\varepsilon$) or clockwise ($-\varepsilon$) viewed in the direction of illumination. If retro reflective materials or devices have a marking (e.g. TOP), this marking governs the starting position. The angle of rotation ε lies in the range $-180^\circ < \varepsilon \leq 180^\circ$.

3.4 Definition of photometric terms

- 3.4.1 “**Coefficient of retro-reflection R**” coefficient (R’) obtained from the luminous intensity” (I) of the retro-reflective area in the direction of observation and the illuminance (E ⊥)on the retro-reflective plane at right angles the direction of the incident light and the illuminated plane sample surface A

$$R' = I / (E_{\perp} * A)$$

The coefficient is of retro-reflective R’ is expressed in candle per square meter per lux (cdm⁻². lx⁻¹).

- 3.4.2 “**Angular diameter of the retro-reflective sample (Symbol h)**” the angle subtended by the greatest dimension of the retro-reflective sample, either at the center of the source of illumination or at the center of the receiver.

- 3.4.3 “**Luminance factor**” the ratio of the luminance of the body considered to the luminance of a perfect diffuser under identical conditions of illumination and observation.

3.5 Fluorescence

When certain substances are brought near to a source of ultraviolet or blue radiations, they emit radiations which are nearly always of longer wavelength than those producing the effect. This phenomenon is called fluorescence. By day and in twilight, fluorescent colors are brighter than normal colors because they reflect part of the light falling upon them and in addition they emit light. At night, they are not brighter than ordinary colors.

3.6 Description of goniometer

A goniometer, which can be used in making retro-reflection measurements in the CIE geometry, is illustrated in annex 1, figure 3. In this illustration, the photometer head is arbitrarily shown to be vertically above the source. The first axis is shown to be fixed and horizontal and is situated perpendicular to the observation half-plane. Any arrangement of the components, which is equivalent to the one shown, can be used.

3.7 Definition of "type"

Rear marking plates of different types means marking plates, which differ, in such essential respects as:

- 3.7.1 The trade name or mark.
- 3.7.2 The characteristics of the retro-reflective material or devices.
- 3.7.3 The characteristics of the fluorescent material.
- 3.7.4 The parts affecting the properties of the retro-reflective material or devices.

4. Technical Information To Be Submitted By The Manufacturer

- 1. Manufacturer’s name & address

2. Telephone No
3. FAX. No.
4. E mail address
5. Contact person
6. Plant/(s)of manufacture.
7. The intended function(s) of the device.
8. The application for approval of a type of rear marking plate shall be submitted by the holder of the trade name or mark, or if necessary by his duly accredited representative and shall be accompanied by:
 - 8.1 Authenticated drawings, in duplicate, sufficiently detailed to permit identification of the type. The drawings shall show geometrically the position in which the rear marking plate is to be fitted to the rear end of the vehicles.
 - 8.2 A brief description giving the technical specifications of the materials of which the retro-reflective areas are made.
 - 8.3 Samples of the retro-reflective and fluorescent (Class 1) or retro-reflective only (Class 2) areas; the number of samples to be submitted is specified in Annex 2

5. MARKINGS

- 5.1 Every rear marking plate submitted for approval shall bear:
 - 5.1.1 The trade name of the applicant and unique mark of type.
 - 5.1.2 On the plates whose retro-reflective system is not omni-rotational, the word "TOP" inscribed horizontally on the part of the plates which is intended to be the highest part of the plate when mounted on the vehicle.
- 5.2 The markings shall be applied on either the retro-reflective or the fluorescent area of the plate, or on the edge, and shall be visible from the outside when the marking plate is fitted on the vehicle.
- 5.3 The markings shall be clearly legible and shall be indelible.

6. CLAUSE RESERVED

7. GENERAL SPECIFICATIONS

- 7.1 Rear marking plates shall be so constructed that they function satisfactorily and will continue to do so in normal use. In addition, they shall not have any defect in design or manufacture that is detrimental to their efficient operation or to their maintenance in good condition.
- 7.2 The components of retro-reflective /fluorescent rear marking plates (class 1) or retro-reflective only rear marking plates (class 2) shall not be capable of being easily dismantled.

- 7.3 The means of attachment of the rear marking plate shall be such that they allow a stable and durable connection between the plate and the rear end of vehicles, for instance by screws or rivets.
- 7.4 The outer surface of the retro-reflective /fluorescent rear marking plate (class 1) or retro-reflective only rear marking plate (class 2) shall be easy to clean. The surface shall therefore not be rough and any protuberances it may exhibit shall not prevent easy cleaning.

8. SPECIAL SPECIFICATION (TESTS)

- 8.1 SMV rear marking plates shall also satisfy the conditions as to dimensions, shape, pattern and the colorimetric, photometric, physical and mechanical requirements set forth in Annexes 3 to 9 of this standard.
- 8.2 Guidelines for installation of rear marking plates (rear warning triangles) for slow moving vehicles (by construction), agricultural tractors, their trailers and semi-trailers shall be as per Annex 12

9. MODIFICATIONS AND EXTENSION OF APPROVAL OF REAR MARKING PLATE (REAR WARNING TRIANGLE)

- 9.1 Every modification pertaining to the information, even if the changes are non-technical in nature declared in accordance to para 4 above, shall be intimated to the test agency by the manufacturer.
- 9.2 If the changes are in parameters not related to the provisions, no further action needs to be taken
- 9.3 If the changes are in parameters related to the provisions, the testing agency, which has issued the certificate of compliance, may then consider, whether:
- 9.3.1 The type with the changed specification still complies with the provisions, or
- 9.3.2 Any further verification is required to establish compliance
- 9.4 For deciding whether testing is required or not: - till details for Criteria for Extension of Approval are finalized, this shall be as agreed between the test agency and the manufacturer.
- 9.5 In case of 9.3.2, only tests pertaining to the affected specification shall be performed.
- 9.6 In case of fulfillment of criterion as per 9.3, the approval of compliance shall be extended for the changes carried out.

10. CONFORMITY OF PRODUCTION

The conformity of production procedures shall comply with those set out in the AIS-037 with following requirements;

- 10.1 Rear marking plate approved to this standard shall be so manufactured as to conform to the type approved by meeting the requirements set forth in paragraphs 7 and 8 above.
- 10.2 The minimum requirements for conformity of production control procedures set forth in Annex 10 to this standard shall be complied with.
- 10.3 The minimum requirements for sampling by an inspector set forth in Annex 11 to this standard shall be complied with.
- 10.4 The test agency may at any time verify the conformity control methods applied in each production facility as detailed in AIS-037. The normal frequency of these verification shall be as per AIS-037 or as decided by CMVR-TSC.

Annex 1
(See 3.3)
THE CIE CO-ORDINATE SYSTEM

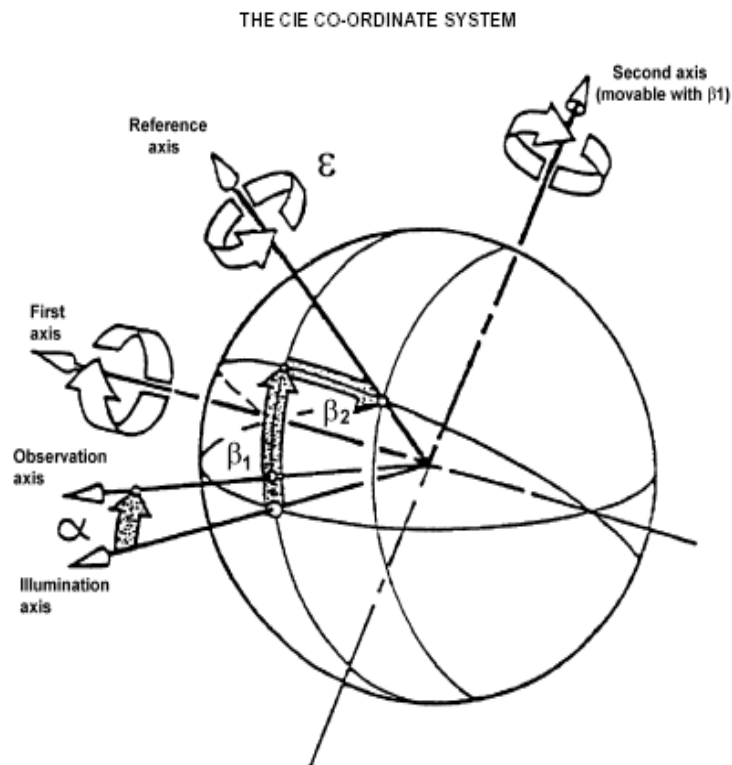

Figure 1

The CIE angular system for specifying and measuring retro-reflectors. The first axis is perpendicular to the plane containing the observation axis and the illumination axis. The second axis is perpendicular both to the first axis and to the reference axis. All axes, angles and directions of rotation are shown positive.

- Note:
- a) The principal fixed axis is the illumination axis.
 - b) The first axis is fixed perpendicular to the plane containing the observation and illumination axis.
 - c) The reference axis is fixed in retro-reflector and movable with β_1 and β_2 .

GONIOMETER MECHANISM EMBODYING THE CIE ANGULAR SYSTEM

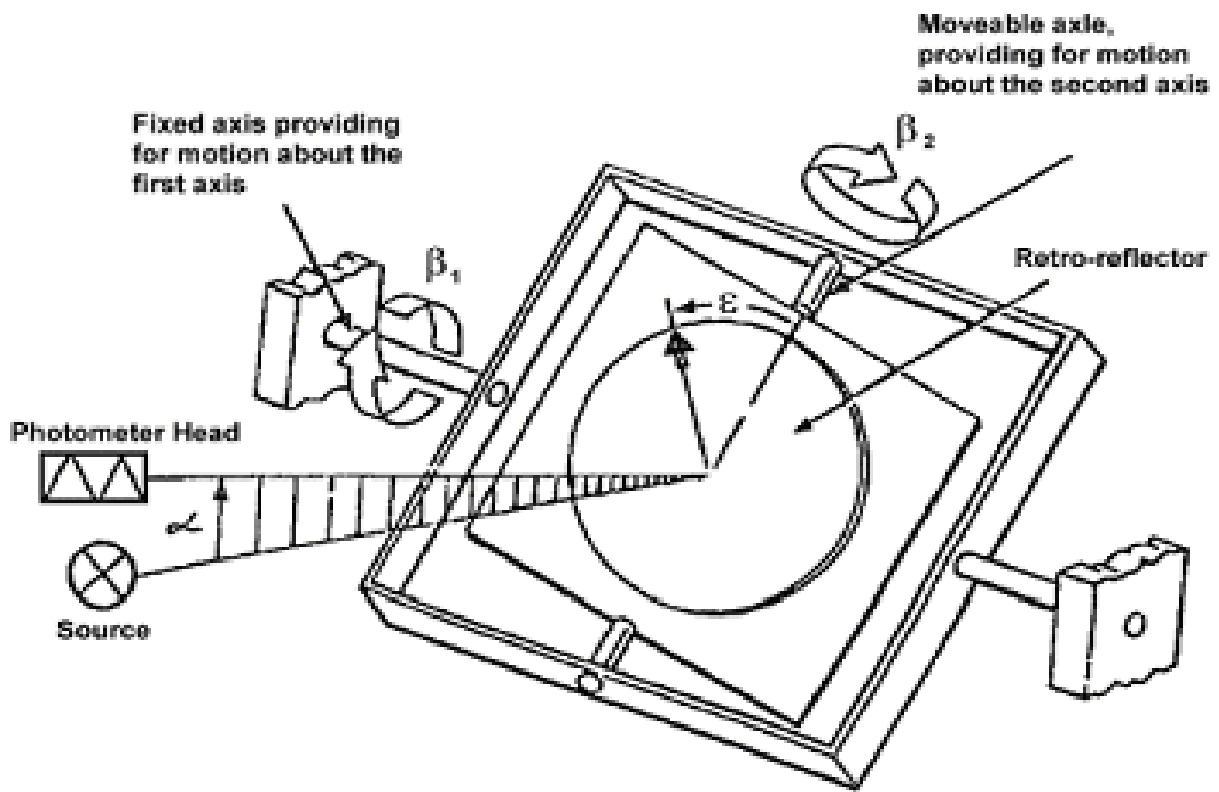

Figure 2

Representation of a goniometer mechanism embodying the CIE angular system for specifying and measuring retro-reflectors. All angles and directions of rotation are shown positive.

TEST PROCEDURE

TEST SAMPLES

1. Five rear marking plates shall be supplied to the testing laboratory for the various tests to be conducted.
2. The test samples shall be representative of current production, fabricated in accordance with the recommendations of the manufacturer(s) of the retro-reflective and fluorescent (class 1) or retro-reflective only (class 2) materials or devices.
3. After verification of the general specifications (paragraph 7 of the Standard) and the specifications of shape and dimensions (Annex 3) four samples shall be subjected the heat resistance test described in Annex 7 to this Standard, prior to the tests described in annexes 4, 5 and 6. The fifth sample shall be kept for reference purposes during the test procedures.
4. The photometric and colorimetric measurements may be made on the same sample.
5. For the other tests, samples which have not undergone any testing should be used.

Annex 3

SPECIFICATIONS OF SHAPE AND DIMENSIONS

**SHAPE AND DIMENSIONS OF RETROREFLECTIVE/FLUORESCENT (CLASS 1)
OR RETRO-REFLECTIVE ONLY (CLASS 2) REAR MARKING PLATES.**

1. Shape: The plates shall be in the shape of an equilateral triangle with truncated corners, for mounting with one apex upwards at the rear of vehicles.
2. Pattern: The plates shall have Red fluorescent center and red retro-reflective borders made of either retro-reflective sheeting or coating or of plastic corner-cube reflectors (class1). The rear marking plates of class 2 shall have a retro-reflective center.
3. The dimension of rear marking plate shall be as per figure 1 in Annex 9
- 3.1 In case of agricultural tractors, if the structure of the tractor makes it impossible to maintain the dimensions as per Figure 1 in Annex 9, it may be suitably modified, provided that each side is not less than 200 mm.

Annex 4

COLORIMETRIC SPECIFICATIONS

1. SMV rear marking plates for vehicles and their trailers shall be composed either of red retro-reflective and orange fluorescent materials or devices (class 1) or red retro-reflective only materials or devices (class 2).
2. Red retro-reflective material or devices
 - 2.1 When measured with a spectrophotometer in accordance with the provisions of CIE document No. 15 (1971) and illuminated with the CIE Standard Illuminant D₆₅ at an angle of 45° to the normal and viewed along the normal (45/0 geometry), the colour of the material in new condition shall be located within the area defined by the chromaticity co-ordinates in Table 1 and comply with the luminance factor.

Table 1

Colour Red	1	2	3	4	Luminance factor
X	0.690	0.595	0.560	0.650	≤ 0.3
Y	0.310	0.315	0.350	0.350	

When illuminated by the CIE Standard Illuminant A at an entrance angle $\beta_1 = \beta_2 = 0^\circ$ or, if this produces a colourless surface reflection, an angle $\beta_1 = \pm 5^\circ$, $\beta_2 = 0^\circ$, and measured at an observation angle of 20', the colour of the material in new condition shall be located within the area defined by the chromaticity co-ordinates in Table 2.

Table 2

Colour Red	1	2	3	4
X	0.720	0.735	0.665	0.643
Y	0.258	0.265	0.335	0.335

Note: The question of the night-time colors of retro-reflective materials is at present being studied by CIE/TC/1.6; the above limits are therefore only provisional and will be revised later after CIE/TC/1.6 has completed its work.

3. Orange / Red fluorescent material
 - 3.1 When measured with a spectrophotometer in accordance with the provisions of CIE document No. 15 (1971) and illuminated polychromatically with the CIE Standard

Illuminant D₆₅ at an angle 45° to the normal and viewed along the normal (geometry 45/0), the colour of the material in new condition shall be located within the area defined by the chromaticity co-ordinates in table/3 and comply with the luminance factor.

Table 3

Colour	1	2	3	4	Luminance factor
Orange					
X	0.690	0.595	0.569	0.655	≥ 0.30
Y	0.310	0.315	0.341	0.345	

4. Compliance with the colorimetric specifications shall be verified by a visual comparison test.

If any doubt remains after this test, conformity with the colorimetric specification shall be verified by determining the trichromatic co-ordinates of the most doubtful sample.

Annex 5

PHOTOMETRIC SPECIFICATIONS

Photometric properties

1. When illuminated with a CIE Standard Illuminant/A and measured as recommended by CIE/TC/2.3 (CIE Publication No./54, 1982), the coefficient of retro-reflection R' in candelas per square meter per lux of the entire red retro-reflective area in new condition shall be at least as indicated in Table 1.

Table 1
Coefficient of retro-reflection R' (cd. m⁻² . lx⁻¹)

Observation angle (α)	Entrance angle (β) in degrees				
	β1	0	0	0	0
1/3°(20')	β2	5	20	30	40
	R' of the outer border (class 1, 2) (cd. m ⁻² . lx ⁻¹)	120	60	30	10
R' of the enclosed triangle (class 2) (cd. m ⁻² . lx ⁻¹)	10	7	4	-	

2. The subtended angle at the sample shall not be larger than 80'.

Annex 6

RESISTANCE TO EXTERNAL AGENTS

1. Resistance to weathering

- 1.1 Procedure - For each test, two specimens of a sample unit (see paragraph 3.1.2 of this Standard) are taken. One specimen shall be stored in a dark and dry container for subsequent use as "reference unexposed specimen".

The second specimen shall be subjected to a source of illumination in accordance with ISO Standard/105-B02-1978, Section 4.3.1; the retro-reflective material shall be exposed until blue standard No. 7 has faded to No. 4 on the gray scale and the fluorescent material until blue standard No. 5 has faded to No. 4 on the gray scale.

After the test, the specimen shall be washed in a dilute neutral detergent solution, dried and examined for conformity with the requirements specified in paragraphs 1.2 to 1.4.

- 1.2 Visual appearance - No area of the exposed specimen shall show any evidence of cracking, sealing, pitting, blistering, delamination, distortion, chalking, staining or corrosion.

There shall be no shrinkage in excess of 0.5 per cent in any linear direction and no evidence of adhesion failure such as edge lifting from the substrate.

- 1.3 Colour fastness - The colors of the exposed specimen shall still meet the requirements in annex 4, tables 1, 2 and 3.

- 1.4 Effect on the coefficient of retro-reflection of the retro-reflective material.

- 1.4.1 For this check, measurement shall be made only at an observation angle of 20' and an entrance angle of 5° by the method given in annex 5.

- 1.4.2 The coefficient of retro-reflection of the exposed specimen when dry shall be not less than 80 per cent of the value in annex 5, table 1.

- 1.4.3 The specimen shall then be subjected to simulated rainfall and its coefficient of retro-reflection under this condition shall be not less than 90 per cent of the value obtained when measured in dry condition, as explained in paragraph 1.4.2 above.

2. Resistance to corrosion (ISO Standard 3768)

- 2.1 A specimen of the sample unit shall be subjected to the action of a saline mist for 48 hours comprising two periods of exposure of 24 hours each, separated by an interval of 2 hours during which the specimen is allowed to dry.

The saline mist shall be produced by atomizing at a temperature of $35 \pm 2^{\circ}\text{C}$ of a saline solution obtained by dissolving five parts by weight of sodium chloride in 95 parts of distilled water containing not more than 0.02 per cent of impurities.

- 2.2 Immediately after completion of the test, the sample shall show no sign of corrosion liable to impair the efficiency of the device.
- 2.2.1 The coefficient of retro-reflection R' of the retro-reflective area, when measured after a recovery period of 48 hours as specified in annex 5, paragraph 1, at an entrance angle of 5° and an observation angle of $20'$, shall be not less than the value in Annex 5, Table 1. Before measuring, the surface shall be cleaned to remove salt deposits from the saline mist.

3. Resistance to fuels

A section of a sample unit not less than 300 mm long shall be immersed in a mixture of n-heptane and toluol, 70 per cent and 30 per cent by volume, for one minute.

After removal, the surface shall be wiped dry with a soft cloth and shall not show any visible change which would reduce its effective performance.

4. Bonding strength (in the case of adhesive materials)

- 4.1 The adhesion of retro-reflective materials shall be determined after 24 hours curing time by utilizing a 90-degree peel on a tensile strength testing machine."
- 4.2 The coated materials, of whatever kind, shall not be removable without tools or without damaging the material.
- 4.3 The laminated materials (adhesive films) shall need a force of at least 10 N per 25 mm width at a speed of 300 mm per minute, to be removed from the substrate.

5. Resistance to water

A section of a sample unit not less than 300 mm long shall be immersed in distilled water at a temperature of $23 \pm 5^{\circ}\text{C}$ for a period of 18 hours; it shall then be left to dry for 24 hours under normal laboratory conditions.

After completion of the test, the section shall be examined. No part inside 10 mm from the cut edge shall show evidence of deterioration which would reduce the effectiveness of the plate.

6. Resistance to impact (except for plastics corner-cube reflectors)

When a 25 mm diameter solid steel ball is dropped from a height of 2 m on to the retro-reflective and on the fluorescent surfaces of a supported plate, at an ambient temperature of $23 \pm 2^{\circ}\text{C}$, the materials shall show no cracking or separation from the substrate at a distance of more than 5 mm from the impacted area.

7. Cleaning

7.1 A test sample smeared with a mixture of detergent lubricating oil and graphite shall be easily cleaned without damage to the retro-reflective or fluorescent surfaces when wiped with a mild aliphatic solvent such as n-heptane, followed by washing with a neutral detergent.

7.2.1 When subjected to a continuous spraying action for 60 seconds on the test component in its normal mounting conditions, a test sample shall show no damage to the retro-reflective surface or delamination from the substrate or separation from the sample mounting surface under the following set-up parameters:

- (a) Water/wash solution pressure 8 ± 0.2 MPa;
- (b) Water/wash solution temperature $60^{\circ} - 5^{\circ}\text{C}$;
- (c) Water/wash solution flow rate 7 ± 1 l/min;
- (d) The tip of the cleaning wand to be positioned at distance of 600 ± 20 mm away from the retro-reflective surface;
- (e) Cleaning wand to be held at no greater angle than 45 degrees from perpendicular to the retro-reflective surface;
- (f) 40 degree nozzle creating wide fan pattern.

Annex 7

RESISTANCE TO HEAT

1. The four samples shall be kept for 48 hours in a dry atmosphere at a temperature of $65 \pm 2^{\circ}\text{C}$, after which the samples shall be allowed to cool for 1 hour at $23 \pm 2^{\circ}\text{C}$. They shall then be kept for 12 hours at a temperature of $-20 \pm 2^{\circ}\text{C}$.
 - 1.1 The sample shall be examined after a recovery time of 4 hours under normal laboratory conditions.
 2. After this test, no cracking or appreciable distortion of the surfaces, particularly of the optical units, shall be evident.
-

Annex 8

RIGIDITY OF THE PLATES

The triangular plate shall be strongly held on one of its long sides, with the clamps of the holding device not encroaching over more than 20 mm. A force of 10N perpendicular to the plane shall be applied to the opposite apex.

The apex shall then not move in the direction of the force by more than 40 mm.

After removal of the force, the plate shall visibly return to its initial position. The residual deflection shall not be more than 5 mm.

Annex 9

SHAPE AND DIMENSION OF REAR MARKING PLATES (REAR WARNING TRIANGLE) FOR AUTOMOTIVE VEHICLES, AGRICULTURAL TRACTORS, THEIR TRAILERS AND SEMI-TRAILER

Example

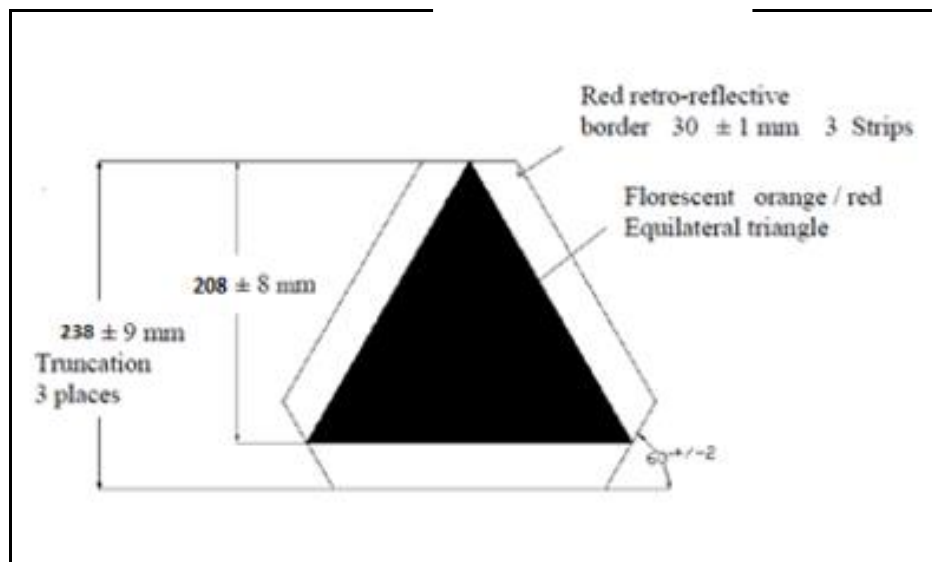
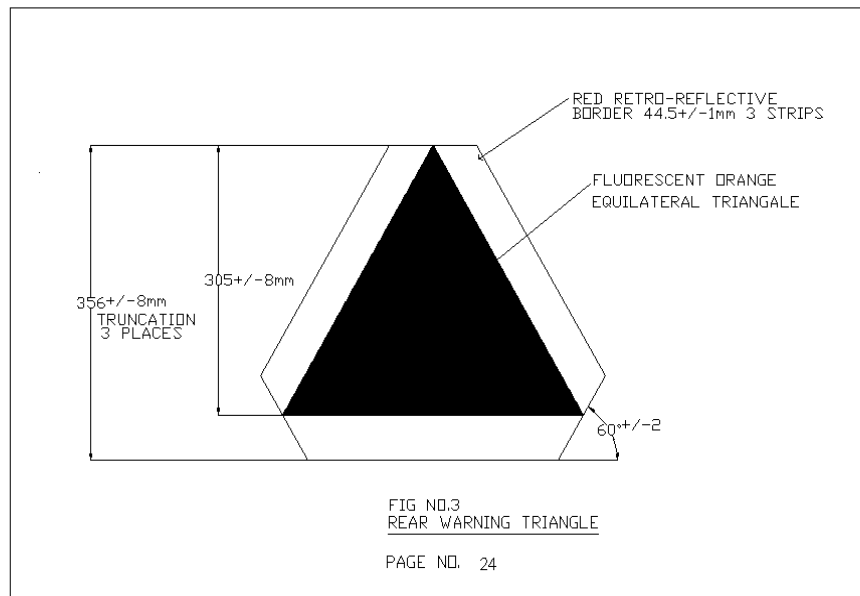

Figure

All dimensions in mm

Annex 10

MINIMUM REQUIREMENTS FOR CONFORMITY OF PRODUCTION CONTROL PROCEDURES

1. GENERAL

- 1.1. The conformity requirements shall be considered satisfied from a mechanical and geometric standpoint, if the differences do not exceed inevitable manufacturing deviations within the requirements of this Standard.
- 1.2. With respect of photometric performances, the conformity of mass-produced rear marking plates shall not be contested if, when testing photometric performances of any rear marking plate chosen at random, no measured value deviates unfavourably by more than 20% from the values prescribed in this Standard.
- 1.3. The chromaticity coordinates shall be complied with.

2. MINIMUM REQUIREMENTS FOR VERIFICATION OF CONFORMITY BY THE MANUFACTURER

For each type of rear marking plate the holder of the approval mark shall carry out at least the following tests, at appropriate intervals. The tests shall be carried out in accordance with the provisions of this Standard.

If any sampling shows non-conformity with regard to the type of test concerned, further sampling shall be taken and tested. The manufacturer shall take steps to ensure the conformity of the production concerned.

2.1. Nature of Tests

Tests of conformity in this Standard shall cover the photometric and colorimetric characteristics and the test of weather resistance of these characteristics.

2.2. Methods used in Tests

- 2.2.1. Tests shall generally be carried out in accordance with the methods set out in this Standard.
- 2.2.2. In any test of conformity carried out by the manufacturer, equivalent methods may be used with the consent of the competent authority responsible for approval tests. The manufacturer is responsible for proving that the applied methods are equivalent to those laid down in this Standard.
- 2.2.3. The application of Paragraphs 2.2.1 and 2.2.2 requires regular calibration of test apparatus and its correlation with measurements made by a competent authority.

2.2.4 In all cases the reference methods shall be those of this Standard, particularly for the purpose of administrative verification and sampling.

2.3. **Nature of Sampling**

Samples of rear marking plates shall be selected at random from the production of a uniform batch. A uniform batch means a set of rear marking plates of the same type, defined according to the production methods of the manufacturer. The assessment shall in general cover series production from individual factories. However, a manufacturer may group together records concerning the same type from several factories, provided these operate under the same quality system and quality management.

2.4. **Measured and Recorded Photometric Characteristics**

The sampled rear marking plate shall be subjected to photometric measurements for minimum values at the points and chromaticity coordinates provided for in the Standard.

2.5. **Criteria Governing Acceptability**

The manufacturer is responsible for carrying out a statistical study of the test results and for defining, in agreement with the competent authority, criteria governing the acceptability of his products in order to meet the specifications laid down for verification of conformity of products in Paragraph 10.1 of this Standard.

The criteria governing the acceptability shall be such that, with a confidence level of 95%, the minimum probability of passing a spot check in accordance with Annex 11 (first sampling) would be 0.95.

Annex 11

MINIMUM REQUIREMENTS FOR SAMPLING BY AN INSPECTOR

1. GENERAL

The conformity requirements shall be considered satisfied from a mechanical and a geometric standpoint, in accordance with the requirements of this Standard, if any, if the differences do not exceed inevitable manufacturing deviations.

- 1.2. With respect to photometric performance, the conformity of mass-produced rear marking plates shall not be contested if, when testing photometric performances of any rear marking plate chosen at random:
 - 1.2.1. No measured value deviates unfavorably by more than 20% from the values prescribed in this Standard.
 - 1.2.2. Rear marking plates with apparent defects are disregarded.
- 1.3. The chromaticity coordinates shall be complied with.

2. SAMPLING

In the first sampling four rear marking plates are selected at random. The first sample of two is marked A, the second sample of two is marked B.

- 2.1. The Conformity is not Contested
Following the sampling procedure shown in Figure 1 of this annex the conformity of mass-produced rear marking plates shall not be contested if the deviation of the measured values of the rear marking plates in the unfavorable directions are:

2.1.1.1. Sample A

A1:	one rear marking plate	0%
	one rear marking plate not more than	20%
A2:	both rear marking plates more than	0%
	but not more than	20%
	go to Sample B	

2.1.1.2. Sample B

B1:	both rear marking plates	0%
-----	--------------------------	----

The Conformity is Contested

- 2.2.1. Following the sampling procedure shown in Figure 1 of this annex the conformity of mass-produced rear marking plates shall be contested and the manufacturer requested to make his production meet the requirements (alignment) if the deviations of the measured values of the rear marking plates are:

2.2.1.1 Sample A

A3:	one rear marking plate not more than	20%
	one rear marking plate more than	20%

but not more than 30%

2.2.1.2 Sample B

B2:	in the case of A2	
	one rear marking plate more than	0%
	but not more than	20%
	one rear marking plate not more than	20%
B3:	in the case of A2	
	one rear marking plate	0%
	one rear marking plate more than	20%
	but not more than	30%

2.3. Approval Withdrawn

Conformity shall be contested and Paragraph 10 applied if, following the sampling procedure in Figure 1 of this Annex, the deviations of the measured values of the rear marking plates are:

2.3.1. Sample A

A4:	one rear marking plate not more than	20%
	one rear marking plate more than	30%
A5:	both rear marking plates more than	20%

2.3.2 Sample B

B4:	in the case of A2	
	one rear marking plate more than	0%
	but not more than	20%
	one rear marking plate more than	20%
B5:	in the case of A2	
	both rear marking plates more than	20%
B6:	in the case of A2	
	one rear marking plate	0%
	one rear marking plate more than	30%

3. REPEATED SAMPLING

In the cases of A3, B2, B3 a repeated sampling, third Sample C of two rear marking plates and forth Sample D of two rear marking plates, selected from stock manufactured after alignment, is necessary within two months time after the notification.

3.1. The Conformity is not Contested

3.1.1 Following the sampling procedure shown in Figure 1 of this annex the conformity of mass-produced rear marking plates shall not be contested if the deviations of the measured values of the rear marking plates are:

3.1.1.1. Sample C

C1:	one rear marking plate	0%
	one rear marking plate not more than	20%
C2:	both rear marking plates more than	0%
	but not more than	20%
	go to Sample D	

3.1.1.2. Sample D

D1:	in the case of C2	
	both rear marking plates	0%

3.2. The Conformity is Contested

3.2.1. Following the sampling procedure shown in Figure 1 of this annex the conformity of mass-produced rear marking plates shall be contested and the manufacturer requested to make his production meet the requirements (alignment) if the deviations of the measured values of the rear marking plates are:

3.2.1.1. Sample D

D2:	in the case of C2	
	one rear marking plate more than	0%
	but not more than	20%
	one rear marking plate not more than	20%

3.3. Approval Withdrawn

Conformity shall be contested and Paragraph 10 applied if, following the sampling procedure in Figure 1 of this annex, the deviations of the measured values of the rear marking plates are:

3.3.1. Sample C

C3:	one rear marking plate not more than	20%
	one rear marking plate more than	20%
C4:	both rear marking plates more than	30%

3.3.2. Sample D

D3:	in the case of C2	
	one rear marking plate 0 or more than	0%
	one rear marking plate more than	20%

4. RESISTANCE TESTS

Specimens of one of the rear marking plates of Sample A, after sampling procedure in Figure 1 of this annex, shall be tested according to the procedures described in Annexes 6 and 7 to this Standard. The rear marking plate shall be considered acceptable if the tests were passed. However, if the tests on specimens of Sample A did not pass the tests, the two rear marking plates of Sample B shall be subjected to the same procedure and both shall pass the test.

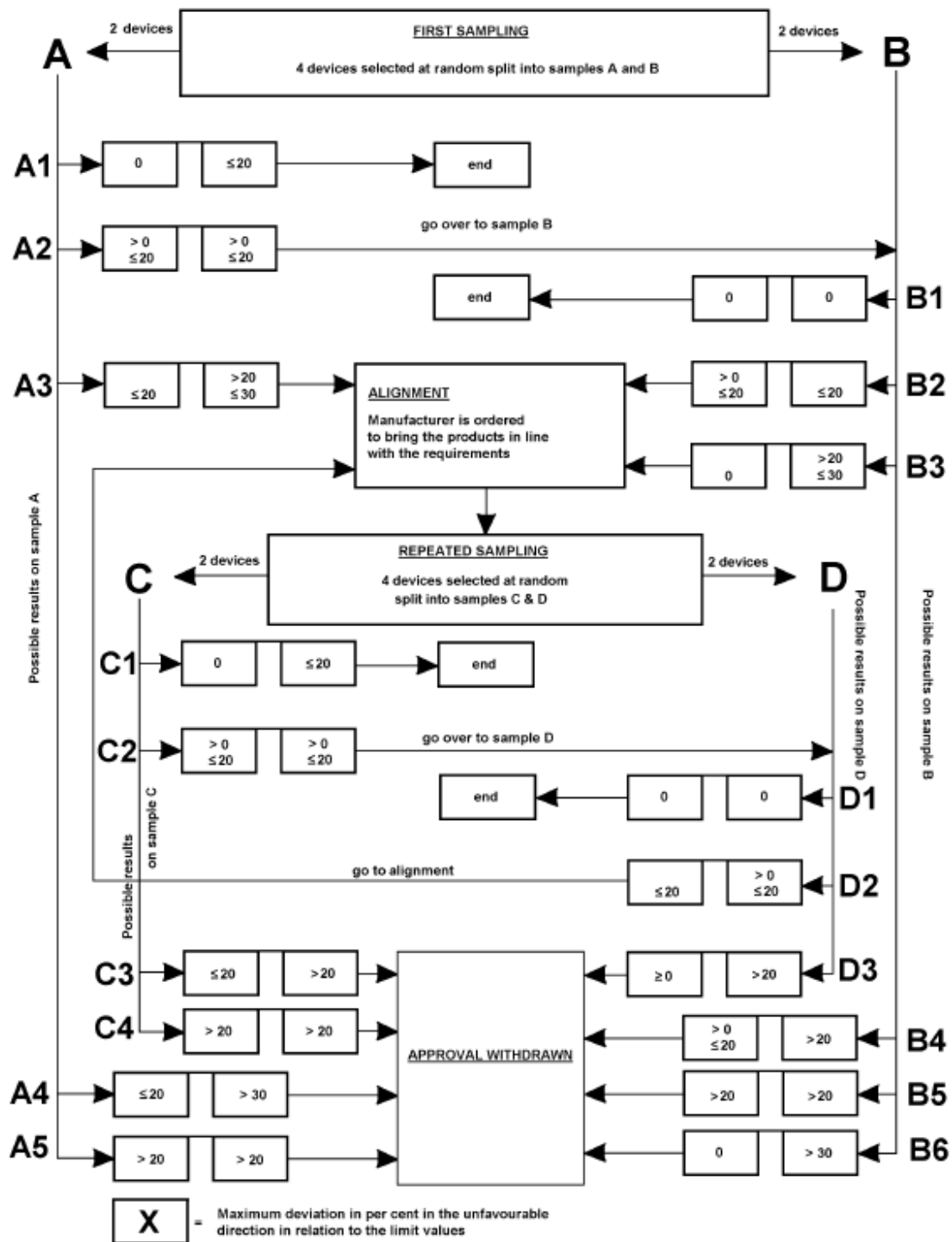

ANNEX 12
(See 8.2)

**GUIDELINES FOR INSTALLATION OF REAR MARKING PLATES
(REAR WARNING TRIANGLES) FOR SLOW MOVING VEHICLES
(BY CONSTRUCTION), AGRICULTURALTRACTORS, THEIR
TRAILERS AND SEMI-TRAILERS**

1. It is recommended to install rear-marking plates (rear warning triangles) confirming to this standard, on slow moving vehicles (by construction), agricultural tractors, their trailers and semi-trailers. The installation shall be in accordance with the guidelines given in this Annex.
2. **Scope**
The main purpose of these guidelines is to establish requirements for installation, arrangement, position and geometric visibility of rear marking plates (rear warning triangles) on slow moving vehicles (SMV) which, by construction, can not travel faster than 40 km/h, agricultural tractors, their trailers and semi-trailers. It increases the visibility and permits an easy identification of these vehicles.
3. Installation requirements of rear marking plates (rear warning triangles) for agricultural tractor shall be as per AIS-030.
4. Installation requirements of rear marking plates (rear warning triangles) for the vehicle categories other than agricultural tractor, within the scope of this standard, shall be as follows:

4.1 **Number**
At least one.

4.2 **Arrangement**
The rear marking plate(s) shall be type approved and meet the requirements of this standard.

The apex of a rear marking plate shall be directed upwards.

Every part of a rear marking plate shall lie within 50 of a transverse vertical plane at right angles to the longitudinal axis of the vehicle and shall face to the rear.

4.3 **Position**

In width: If there is only one rear marking plate, it must be on the right side of the median longitudinal plane of the vehicle.

In height: Above the ground, not less than 250 mm (lower edge), not more than 1,500 mm (upper edge).

In length: At the rear of the vehicle.

4.4 Geometric Visibility

Horizontal angle: 30° inwards and outwards, covering by indispensable constructional parts of the vehicle up to 10% of the rear marking plate surface is permitted;

Vertical angle: 15° above and below the horizontal;

Orientation: rearwards.

ANNEX 13
PANEL COMPOSITION*
(To be included)

ANNEX 14

(See Introduction)
COMMITTEE COMPOSITION *
Automotive Industry Standards Committee
(To be included)